

**Quoi de mieux qu'une
grande marque
pour promouvoir la vôtre ?**

2 0 2 0
CATALOGUE GÉNÉRAL





Un futur durable à écrire ensemble.

L'engagement du Groupe "Writing The Future, Together", formulé en 2017, signe une nouvelle étape dans la démarche engagée par BIC depuis 2004. Ce **programme ambitieux à l'horizon 2025**, qui fait partie intégrante de la stratégie de l'entreprise, engage BIC vers une philosophie **d'action et de transformation** qui influence l'intégralité de l'entreprise.

Cet engagement couvre cinq domaines stratégiques

01 FAVORISER L'INNOVATION DURABLE DANS LES PRODUITS BIC®

Un design simple et inventif, nécessitant peu de matières premières et garantissant une longue durée de vie.

02 AGIR CONTRE LE CHANGEMENT CLIMATIQUE

Le Groupe BIC adopte une approche globale au regard de la consommation énergétique (efficacité énergétique, utilisation d'énergies renouvelables, etc.),

03 S'ENGAGER POUR LA SECURITE AU TRAVAIL

L'objectif du Groupe est d'offrir un environnement de travail sûr et propice au développement.

04 IMPLIQUER LES FOURNISSEURS DE MANIÈRE PROACTIVE

Notre équipe Achats analyse l'ensemble des risques, puis sélectionne nos fournisseurs stratégiques et travaille de concert avec ces derniers en adoptant une démarche responsable.

05 S'INVESTIR POUR UNE VIE MEILLEURE À TRAVERS L'EDUCATION

L'éducation, qui a le pouvoir de changer le monde, a toujours été au centre des préoccupations du Groupe.



Visionnez la vidéo et apprenez-en plus sur le développement durable
www.bicworld.com/fr/nos-engagements/en-bref

Agir contre le ——— — **changement climatique**

Le Groupe BIC adopte une approche globale au regard de la consommation énergétique (efficacité énergétique, utilisation d'énergies renouvelables, etc.), en se fondant sur la feuille de route développée par le Groupe et sur des choix, au niveau local, qui tiennent compte des opportunités. L'utilisation d'une énergie renouvelable contribuera à réduire de manière notable les émissions de gaz à effet de serre générées par BIC d'ici à 2025.

L'ENGAGEMENT DU GROUPE BIC POUR

2025

D'ici à 2025, BIC utilisera
80% d'électricité d'origine
renouvelable.

OÙ SE PLACE BIC GRAPHIC EUROPE EN 2020 ?

L'usine et nos installations d'impression
BIC Graphic de Tarragone sont
alimentées avec de l'électricité

100%

renouvelable.





Visionnez la vidéo
Petit stylo deviendra banc

Ubicity™ : un modèle d'économie circulaire unique

Depuis 2011, le Groupe est associé en Europe à **TerraCycle®**, entreprise pionnière du recyclage des déchets en plastique petits et complexes, pour créer de toute pièce un programme de collecte des instruments d'écriture, quel que soit leur fabricant, sur les lieux mêmes de consommation (écoles, bureaux, etc.). En 2017, BIC a lancé **Ubicity™**, une gamme de mobilier extérieur, fabriquée à partir de cette matière collectée, et commercialisée par la société française Plas Eco auprès des collectivités et de nombreux établissements scolaires.

100 % des instruments d'écriture BIC® sont recyclables grâce à Ubicuity™

1

2

3

VOUS COLLECTEZ



NOUS RECYCLONS



NOUS TRANSFORMONS



<p><u>STYLOS</u></p> <p>26 BIC® Style</p> <p>30 BIC® Round Stic</p> <p>34 BIC® M10 Clic</p> <p>38 BIC® Media Clic</p> <p>42 BIC® Media Clic Grip</p> <p>46 BIC® Media Clic Shine</p> <p>47 BIC® Media Clic Bio Ecolutions</p> <p>52 BIC® Clic Stic</p> <p>62 BIC® Super Clip</p> <p>66 BIC® Super Clip Advance</p> <p>72 BIC® Wide Body</p> <p>74 BIC® Wide Body Chrome</p> <p>80 BIC® Atlantis</p> <p>84 BIC® 4 Colours</p> <p>88 BIC® 4 Colours Mini</p> <p>89 BIC® 4 Colours Sun</p> <p>90 BIC® 4 Colours Fashion</p> <p>92 BIC® 4 Colours Shine</p> <p>94 BIC® 4 Colours Fine</p> <p>95 BIC® 4 Colours Fluo</p> <p>96 BIC® 4 Colours Stylus</p> <p>97 BIC® 4 Colours 3+1</p>	<p><u>ROLLERS ET GELS</u></p> <p>106 BIC® Grip Roller</p> <p>108 BIC® XS Finestyle</p> <p>111 BIC® Atlantis Gel</p> <p>112 BIC® Gel-Ocity Illusion</p> <p>114 BIC® Intensity Gel Clic</p>	<p><u>SPROUT</u></p> <p>139 Sprout</p>
<p><u>STYLOS MÉTALLIQUES</u></p> <p>100 BIC® Metal Pro</p>	<p><u>SURLIGNEURS ET MARQUEURS</u></p> <p>118 BIC® Brite Liner Grip</p> <p>122 BIC® Velleda White Board Marker Fine</p> <p>123 BIC® Velleda White Board Marker Grip</p> <p>124 BIC® Mark-It Permanent Marker</p> <p>125 BIC® Permanent Marker Ecolutions</p>	<p><u>COLORIAGE</u></p> <p>144 BIC® Plastidecor Lot de 6 craies</p> <p>145 BIC® Evolution Ecolutions Lot de 6 crayons</p> <p>146 CONTE Lot de 6 crayons</p> <p>147 BIC® Lot de crayons de coloriage</p> <p>150 CONTE by BIC® Lot de coloriage</p>
	<p><u>CRAYONS</u></p> <p>128 BIC® Matic</p> <p>133 BIC® Evolution Ecolutions</p>	<p><u>CORRECTEUR</u></p> <p>153 TIPP-EX Mini Pocket Mouse BritePix</p>



Instrument d'écriture

26 — 153



BIC® STYLE
Opaque - 1610



01/01 01/03 01/05 01/04 01/02 02/02

Encre de couleur

New colours!



10 03 14 13 04

100%

12

Commande minimale 500u.

Personnalisation :

Transparent
1610



BIC® STYLE

1610

A SP: max. 2 col.

BIC® STYLE CLEAR

1610

B SP: max. 1 col.

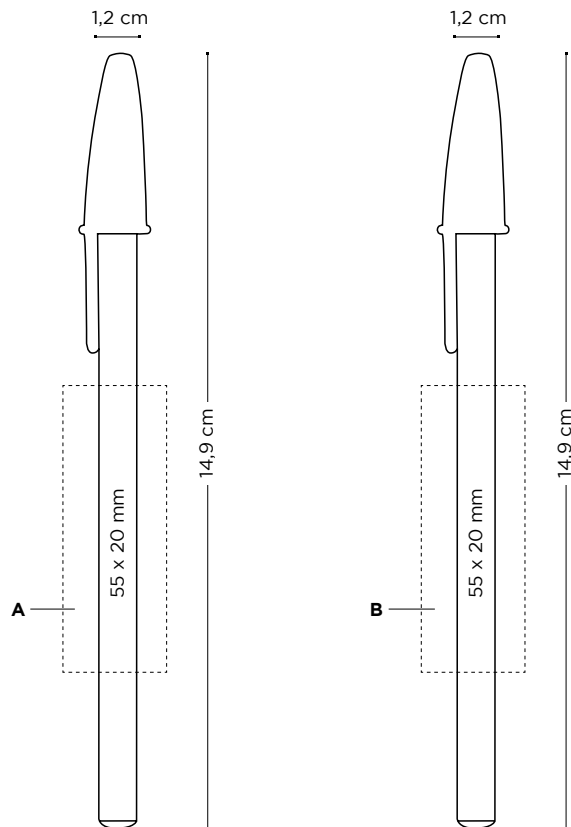

BIC® STYLE / BIC® STYLE CLEAR

1610

SP

① Prix sur demande.

Mode d'écriture :

Bille



M

Techniques d'impression :



(SP)
SÉRIGRAPHIE

Nouvel emballage spécial
en option :



ECO Sleeve / Plastic Pouch

+ INFO pag. 296

Emballage
externe :



500 ± 3,5 Kg

www.bicgraphic.eu

27





L'icône BIC® Round Stic® offre un style indémodable et une très grande qualité. Son design classique est facile à identifier et il est synonyme de fiabilité à long terme.





Opaque - 1010

Givré - 1010

l'icône BIC® BOY est en relief

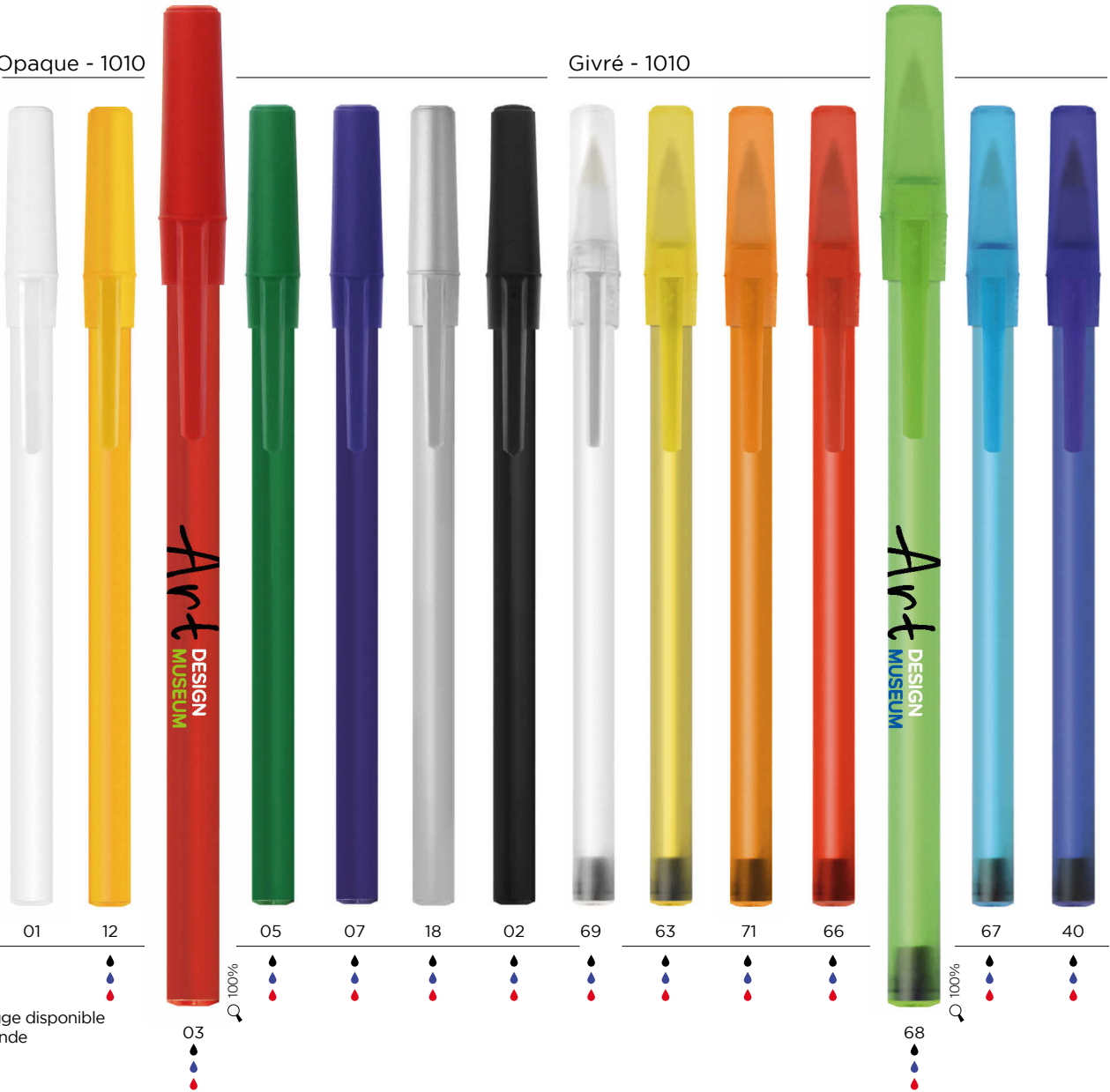

Encre de couleur
Encre rouge disponible sur demande

** 48h non disponible en impression numérique





FABRIQUÉ À PARTIR DE 94%
DE MATÉRIEL RECYCLÉ ET EST
100% RECYCLABLE

ecolutions®
Opaque - 1E10

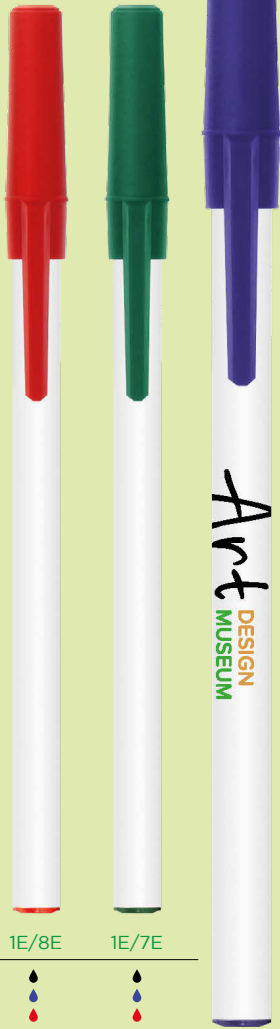

1E/8E

1E/7E

1E/10E



ecolutions®
Givré - 1E10

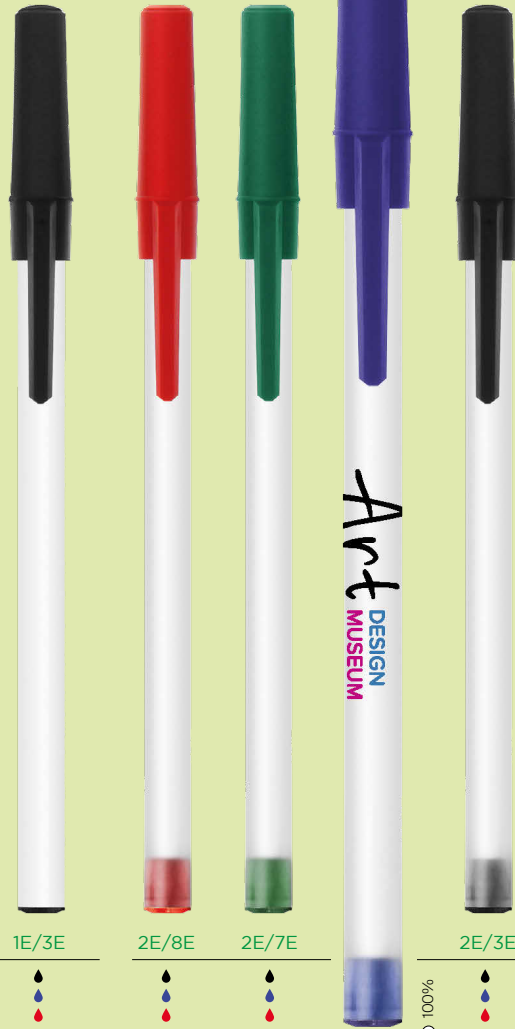

1E/3E

2E/8E

2E/7E

2E/10E



2E/3E

Impression
numérique!

BIC® ROUND STIC® DIGITAL

ecolutions®

VERSION DISPONIBLE
Opaque - 1010/1E10



1E/10E

Disponible en corps blanc

01



Commande minimale 500u.

Combinaison de couleurs standards

Combinaison de couleurs standards
eColutions®

Bouton

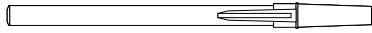

OPAQUE 01 12 10 03 05 20 04 07 18 02

GIVRÉ 69 63 71 66 68 67 40

Clip

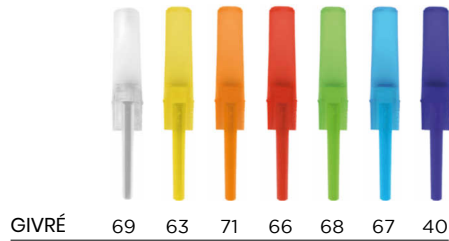
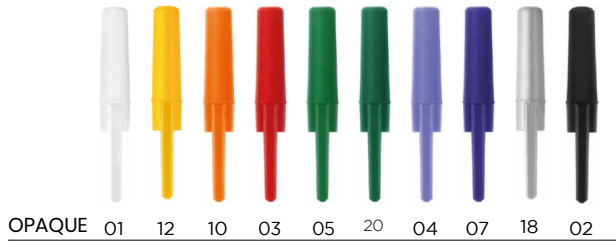
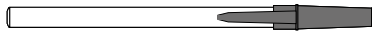

Section

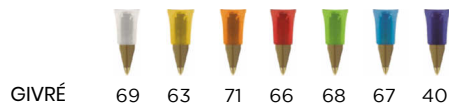
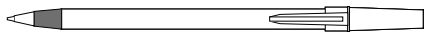

Corps

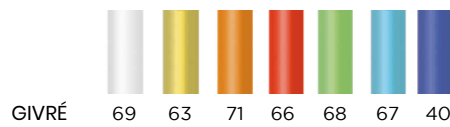
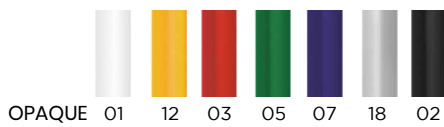

Combinaison de couleurs standards eColutions®

OPAQUE 01 12 10 03 05 20 04 07 18 02

GIVRÉ 69 63 71 66 68 67 40

8E 7E 10E 3E

8E 7E 10E 3E

OPAQUE 01 12 03 05 07 18 02

GIVRÉ 69 63 71 66 68 67 40

1E 2E

Injection d'une couleur spécifique :

≥ 10.000 unités



Ajoutez la boucle mobius sur votre BAT sans frais additionnel. Merci de le préciser dans votre bon de commande (en bas à gauche par défaut)

Mode d'écriture :



M

Techniques d'impression :



(SP) SÉRIGRAPHIE



(DG) NUMÉRIQUE

Nouvel emballage spécial en option :



ECO Sleeve / Plastic Pouch

Emballage externe :



500 ± 2,5 Kg



FABRIQUÉ EN ESPAGNE

+ INFO pag. 296

Personnalisation :

BIC® ROUND STIC®

1010

@COlutions® 1E10

A SP: max. 3 col.

B SP: max. 1 col.

C DG: Numérique (Disponible en corps blanc)

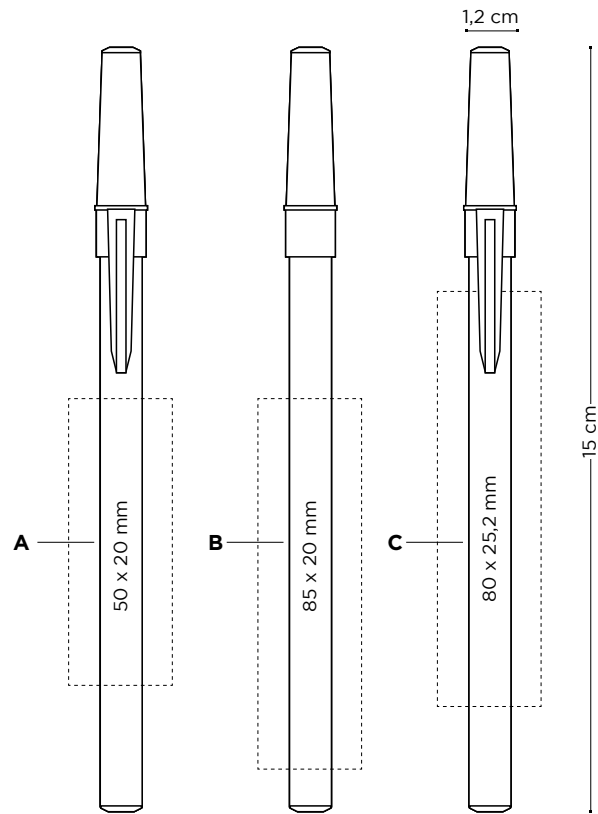



BIC® M10® CLIC
1590



l'icône BIC® BOY est en relief



Bouton-poussoir latéral

Encre de couleur

01

8G

10

14

59

04

02

3D



Commande minimale 500u.

Personnalisation :

BIC® M10® CLIC

1590

A SP: max. 2 col.

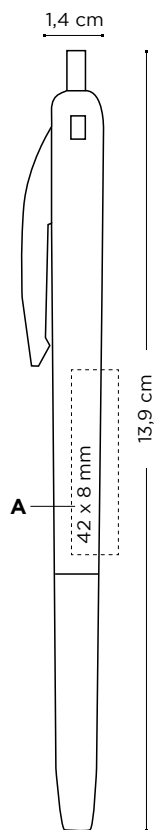

BIC® M10® CLIC

1590

SP

**Mode
d'écriture :**

Bille



M

**Techniques
d'impression :**



(SP)
SÉRIGRAPHIE

**Nouvel emballage
spécial en option :**



ECO Sleeve / Plastic Pouch / Window Box

+ INFO pag. 296

**Emballage
externe :**



1000 ± 8 Kg



Regardez la video



**FABRIQUÉ
EN FRANCE**



Couleur blanche
fabriquée en
Afrique du Sud



Un de nos best-sellers, design fonctionnel et reconnu, notre BIC Media Clic est un produit durable, disponible dans différents matériaux. Vous pouvez choisir entre standard, recyclé et BIO. Laissez-vous porter par la vaste gamme de couleurs et finitions afin de trouver l'équilibre juste pour votre marque.

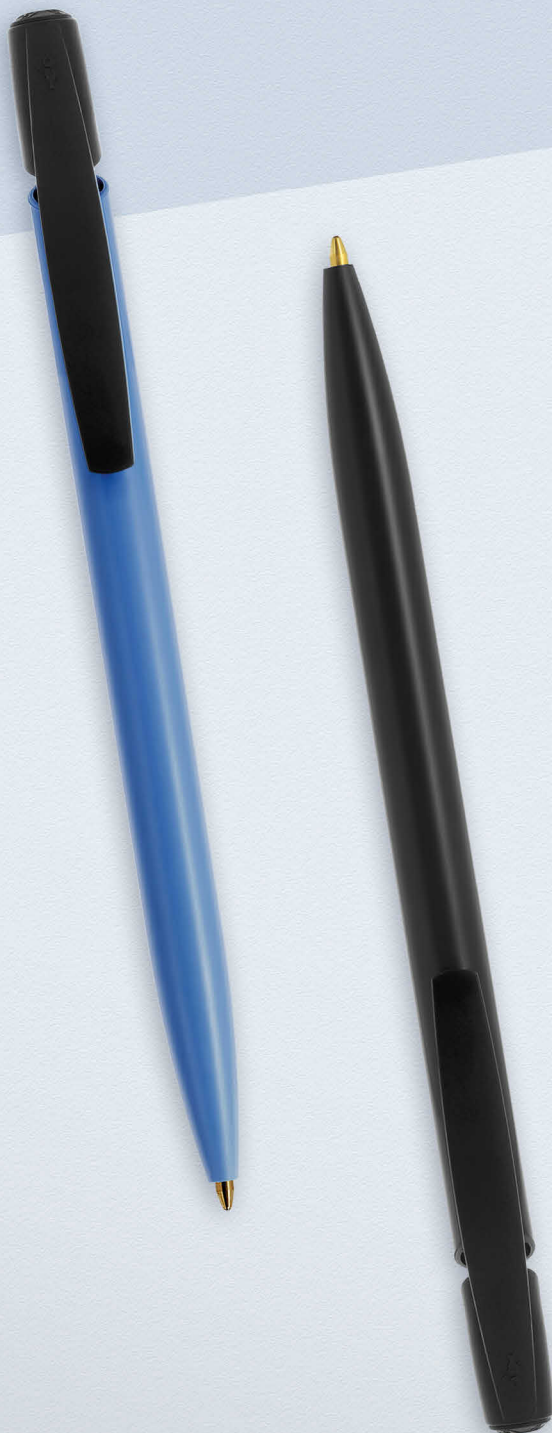

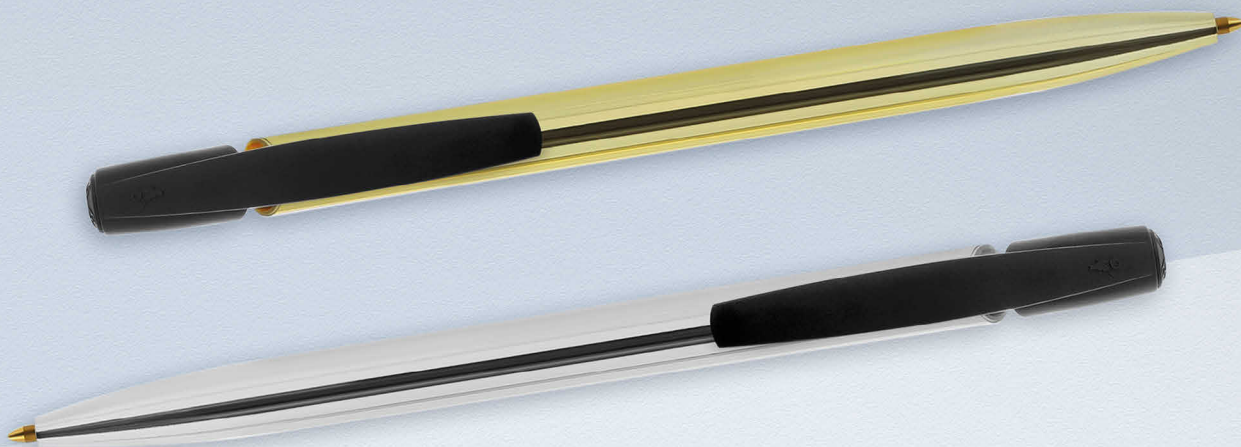



Poli Bille - 1025



 Icône BIC® BOY est en relief



Encre de couleur
 Encre rouge disponible sur demande

* 48h non disponible en impression numérique



Transparent Bille - 1025



Plus de 10 000 clics !





Opaque Bille - 1025 / Crayon 1028



Encre de couleur
Encre rouge disponible sur demande

** 48h non disponible en impression numérique



Givré Bille - 1025 / Crayon 1028

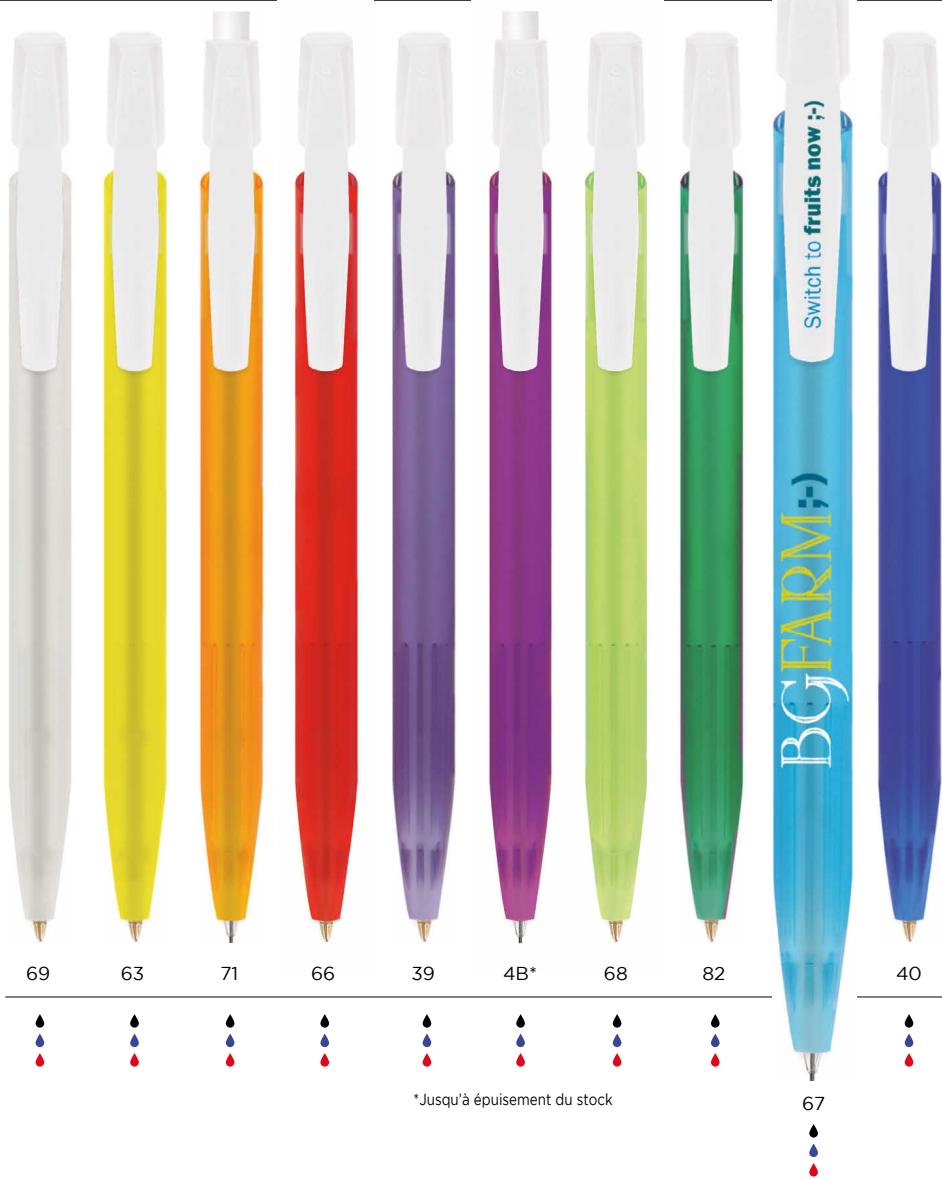

69

63

71

66

39

4B*

68

82

40

67

*Jusqu'à épuisement du stock



FABRIQUÉ À PARTIR
DE 92% DE MATÉRIEL
RECYCLÉ ET EST
100% RECYCLABLE

eColutions®

Opaque

Bille - 1E25

Crayon 1E28



1E

3E

*Pourcentage calculé sur le
poids total du corps du stylo



Opaque Bille - 1020
Crayon 1021

Givré Bille - 1020 / Crayon 1021



01/12



01/03



01/05



01/07



01/02



01/69



69/69



71/69



66/69



82/69



40/69

Encre de couleur

Encre rouge disponible sur demande



** 48h non disponible en impression numérique





FABRIQUÉ À PARTIR DE 50%
DE MATÉRIEL RECYCLÉ ET
EST **100% RECYCLABLE**

ecoolutions®

Opaque Bille - 1E20
Crayon 1E21



*Pourcentage calculé sur le poids total du corps du stylo

Impression numérique!

BIC® MEDIA CLIC DIGITAL

Opaque Bille - 1025
Crayon 1028

Nouveau!

BIC® MEDIA CLIC GRIP DIGITAL

Opaque Bille - 1020 / 1E20
Crayon 1021 / 1E21



Regardez la video



Commande minimale 500u.

Combinaison de couleurs standards  Combinaison de couleurs standards

Plug

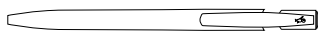

OPAQUE 01 12 10 03 5C 2D 13 84* 85* 5G 05 3D 83* 04 07 18 02 GIVRÉ 69

Clip

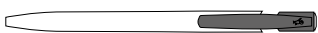

OPAQUE 01 12 10 03 5C 2D 13 84* 85* 5G 05 3D 83* 04 07 18 02 GIVRÉ 69

Corps



OPAQUE 01 12 10 03 5C 2D 13 85* 5G 05 3D 83* 04 07 3C 18 02

Corps et Grip

01/12 01/03 01/05 01/07 01/02

Corps et Grip

GIVRÉ 69 63 71 66 39 4B* 68 82 67 40

01/69 69/69 71/69 66/69 82/69 40/69

BRILLANT 1T 8T 6P 3T 6T 9T 5P 5T 4T 7T 8L 2T

CLEAR 1R 4D 92 87 95 93 88 72 4R 7R 91

Injection d'une couleur spécifique :

≥ 10.000 unités 1025/1028
1E25/1E28
1E20/1E21

≥ 20.000 unités 1020/1021
1E20 digital/1E21 digital

Mode d'écriture :

Techniques d'impression :

			
M	MP Ø0,7mm	(SP) SÉRIGRAPHIE	(DG) DIGITAL

*Jusqu'à épuisement du stock



Ajoutez la boucle mobius sur votre BAT sans frais additionnel. Merci de le préciser dans votre bon de commande (en bas à gauche par défaut)



OPAQUE 1E 3E

Corps et Grip OPAQUE

01/12 01/03 01/05 01/07 01/02

Personnalisation :

BIC® MEDIA CLIC

- 1025 (bille)
- 1028 (crayon)
- ©©olutions® 1E25 (bille)
- ©©olutions® 1E28 (crayon)

- A SP:** max. 4 col.
- B SP:** max. 2 col.
- C DG:** Numérique

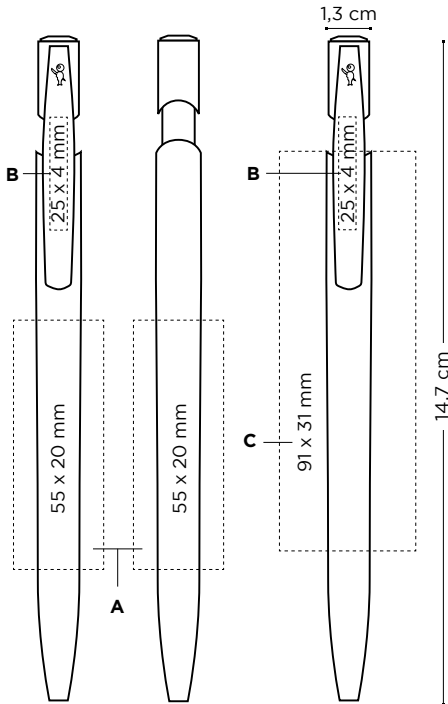

BIC® MEDIA CLIC GRIP

- 1020 (bille)
- 1021 (crayon)
- ©©olutions® 1E20 (bille)
- ©©olutions® 1E21 (crayon)

- D SP:** max. 4 col.
- E SP:** max. 2 col.
- F DG:** Numérique

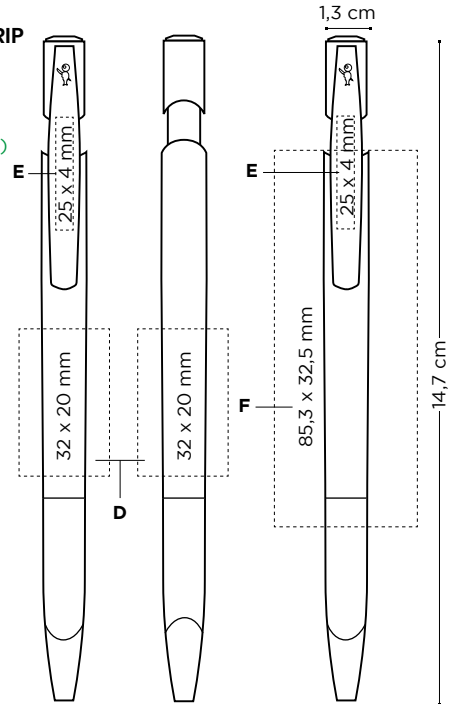

BIC® MEDIA CLIC

1025 / ©©olutions® 1E25 (bille)

SP

DG

1028 / ©©olutions® 1E28 (crayon)

SP

DG

① Prix sur demande.

BIC® MEDIA CLIC GRIP

1020 / ©©olutions® 1E20 (bille)

SP

DG

1021 (crayon) / ©©olutions® 1E21 (crayon)

SP

DG

① Prix sur demande.

Emballage externe :



500 ± 4,1 Kg

Nouvel emballage spécial en option :



ECO Sleeve / Plastic Pouch / Window Box

+ INFO pag. 296

Emballage externe :



500 ± 4,3 Kg

Regardez la video



FABRIQUÉ EN ESPAGNE

Nouveau !

Opaque Ballpen - 1975

MIX & MATCH

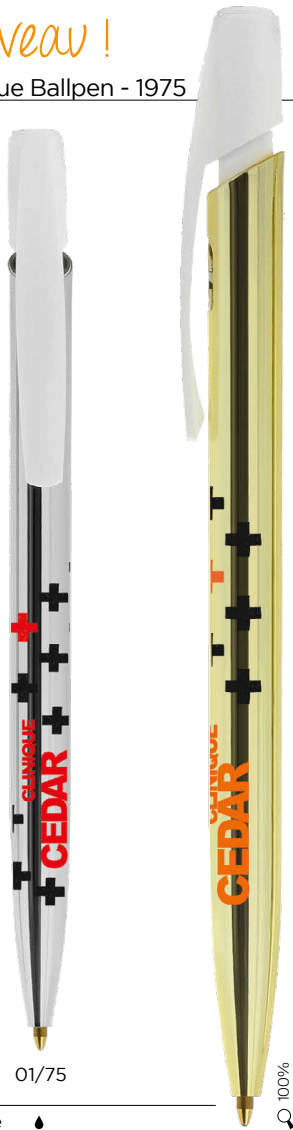

01/75

01/26

Encre de couleur
Encre rouge disponible sur demande

BIC® MEDIA CLIC SHINE

1975
A SP: max. 2 col.
B SP: max. 2 col.

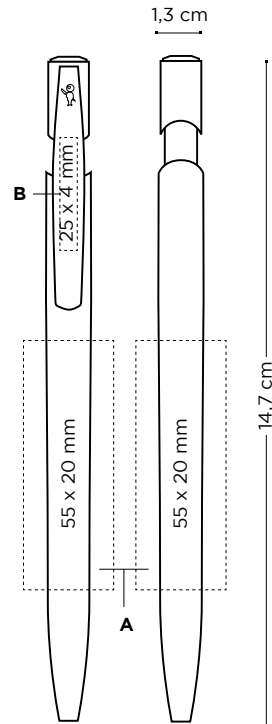

BIC® MEDIA CLIC SHINE

1975

SP
SP (premium)

Commande minimale 500u.

Combinaison de couleurs standards

Plug

OPAQUE 01 12 10 03 5C 2D 13 84 85 5G 05 3D 83 04 07 18 02 GIVRÉ 69 PREMIUM 35

Clip

OPAQUE 01 12 10 03 5C 2D 13 84* 85* 5G 05 3D 83* 04 07 18 02 GIVRÉ 69 SHINE 01/26 01/75

Corps

SHINE

Mode d'écriture :



M

*Jusqu'à épuisement du stock

Techniques d'impression :



(SP) SÉRIGRAPHIE

Nouvel emballage spécial en option :



ECO Sleeve / Plastic Pouch / Window Box

Emballage externe :



500 ± 4,1 Kg



FABRIQUÉ EN ESPAGNE



LA PREMIÈRE PRIORITÉ DE DANS CYCLE DE VIE DU MEDIA CLIC BIO ECOLUTIONS® EST LA DURABILITÉ



STYLO BIODÉGRADABLE:

Plus d'encre dans le stylo?
Pas de soucis, celui-ci est décomposable.
Le corps est **100% biodégradable**
et le clip est **100% recyclable**

MATERIEL BIO:

Le corps est fabriqué à partir de **70% de matériel bio**. Les colorants sont 100% bio.

FAIT POUR DURER:

- Plus de **10,000 clicks**
- Clip incassable

FAIBLE IMPACT DU TRANSPORT:

Production, impression et même **matières premières fabriquées en Europe**

ÉNERGIE RENOUVELABLE:

Produit dans notre usine et nos imprimeries qui sont toutes deux alimentées par **100% d'électricité renouvelable**.

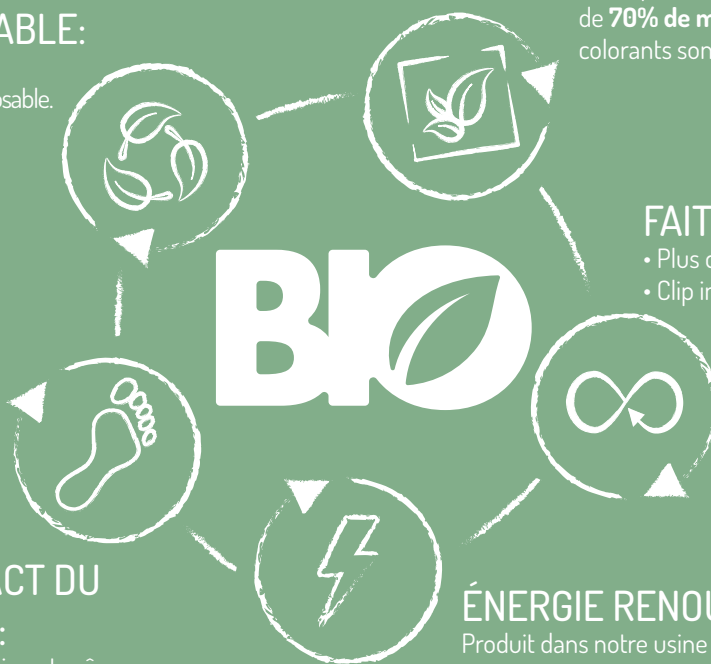

BIO Nouveau !

MIX & MATCH



FABRIQUÉ À PARTIR DE 70% DE MATÉRIEL BIO ET EST **100% BIODÉGRADABLE**

Opaque Ballpen - 1972



01BIO 012BIO 03BIO 05BIO 04BIO 02BIO

Encre de couleur      

Encre rouge disponible sur demande

*Le pourcentage est calculé sur le poids total du corps du style.
Biodégradable selon les conditions industrielles exigées

Commande minimale 500u.

Combinaison de couleurs standards

Plug

OPAQUE 01 12 10 03 5C 2D 13 84 85 5G 05 3D 83 04 07 18 02 GIVRÉ 69

Clip



OPAQUE 01 12 10 03 5C 2D 13 84* 85* 5G 05 3D 83* 04 07 18 02 GIVRÉ 69

Corps

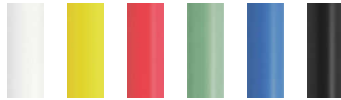

OPAQUE 01BIO 012BIO 03BIO 05BIO 04BIO 02BIO

BIC® MEDIA CLIC BIO
ecosolutions®
 1972
A SP: max. 4 col.
B SP: max. 2 col.

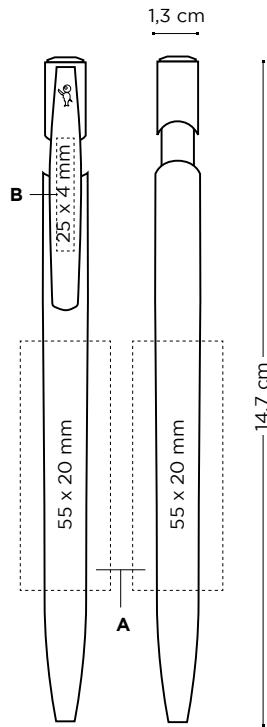

BIC® MEDIA CLIC BIO **eco**solutions®
 1972
 SP

Mode d'écriture :



M

*Jusqu'à épuisement du stock

Techniques d'impression :



(SP)
 SÉRIGRAPHIE

Nouvel emballage spécial en option :



ECO Sleeve / Plastic Pouch / Window Box

Emballage externe :



500 ± 4,3 Kg



FABRIQUÉ EN ESPAGNE



+ INFO pag. 296

www.bicgraphic.eu





Moderne, fiable, flexible. C'est la définition même du BIC® Clic Stic! Une grande variété de finitions telles que Digital, Stylus, Softfeel® ou Mini, et plus de mille combinaisons de couleurs!





Opaque - 1000



01 12 05 04 07 18 02

Encre de couleur

Encre rouge disponible sur demande

03

100%



Micronique BIC® BOY est en relief



FABRIQUÉ À PARTIR DE 78% DE MATÉRIEL RECYCLÉ ET EST 100% RECYCLABLE

ecolutions® Opaque - 1E00



1E/8E 1E/7E 1E/3E

100%



100%



*Pourcentage calculé sur le poids total du corps du stylo
 **48h non disponible en impression numérique

Givré - 1000

Clip résistant
incassable !



FABRIQUÉ À PARTIR
DE 78% DE MATÉRIEL
RECYCLÉ ET EST
100% RECYCLABLE

ecolutions®
Givré
1E00

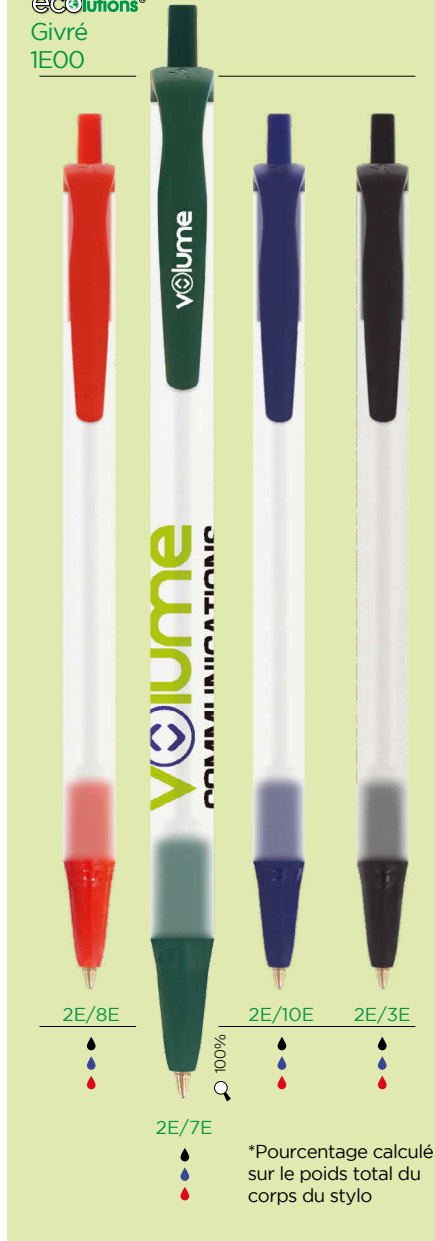

BIC® CLIC STIC MINI
Opaque - 1892





**BIC® CLIC STIC
SOFTFEEL®**
Opaque - 1005

Givré - 1005

**BIC® CLIC STIC
STYLUS**
Opaque - 1847



20

07

40

01

03

04

18

02

Encre de couleur
Encre rouge disponible sur demande

02

07

*48h non disponible en impression numérique



Impression numérique!

**BIC® CLIC STIC
DIGITAL**
Opaque
1000 / 1E00



01
● ● ●
● ● ●

**BIC® CLIC STIC
MINI DIGITAL**
Opaque
1892



01
● ● ●
● ● ●

**BIC® CLIC STIC
STYLUS DIGITAL**
Opaque
1847



01
● ● ●
● ● ●

Uniquement disponible en corps blanc

Commande minimale 500u.

Combinaison de couleurs standards

Bouton



OPAQUE	01	12	10	03	05	20	04	07	18	02	GIVRÉ	69	63	71	66	68	67	40
--------	----	----	----	----	----	----	----	----	----	----	-------	----	----	----	----	----	----	----

Clip

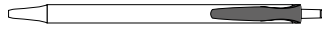

OPAQUE	01	12	10	03	05	20	04	07	18	02	GIVRÉ	69	63	71	66	68	67	40
--------	----	----	----	----	----	----	----	----	----	----	-------	----	----	----	----	----	----	----

Section

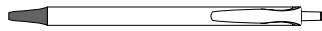

OPAQUE	01	12	10	03	05	20	04	07	18	02
--------	----	----	----	----	----	----	----	----	----	----

stylus

GIVRÉ	69	63	71	66	68	67	40	OPAQUE	02
-------	----	----	----	----	----	----	----	--------	----

Corps



OPAQUE	01	12	03	05	04	07	18	02
--------	----	----	----	----	----	----	----	----

softfeel®

OPAQUE	20	07	02
--------	----	----	----

Mini

OPAQUE	01
--------	----

softfeel®

GIVRÉ	69	63	66	68	67	40	71	OPAQUE	40
-------	----	----	----	----	----	----	----	--------	----

Injection d'une couleur spécifique :

≥ 10.000 unités

Mode d'écriture :

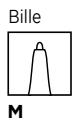

M

Techniques d'impression :



(SP)
SÉRIGRAPHIE



(DG)
NUMÉRIQUE

Commande minimale 500u.

Combinaison de couleurs standards **eC@lutions®**

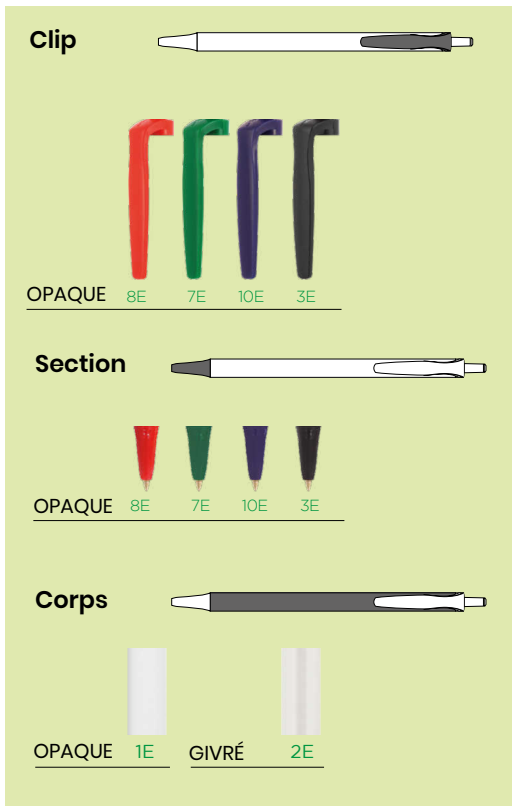
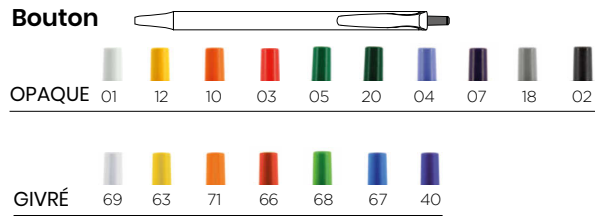

Ajoutez la boucle mobius sur votre BAT sans frais additionnel. Merci de le préciser dans votre bon de commande (en bas à gauche par défaut)

Injection d'une couleur spécifique :

≥ 10.000 unités

Mode d'écriture : **Techniques d'impression :**

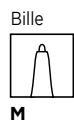

Personnalisation :

BIC® CLIC STIC
1000
eColutions® 1E00

BIC® CLIC STIC STYLUS
1847

- A SP:** max. 3 col.
- B SP:** max. 1 col.
- C SP:** max. 2 col.
- D DG:** Numérique (zone texte)
(Disponible en corps blanc)
- E DG:** Numérique (zone image)
(Disponible en corps blanc)

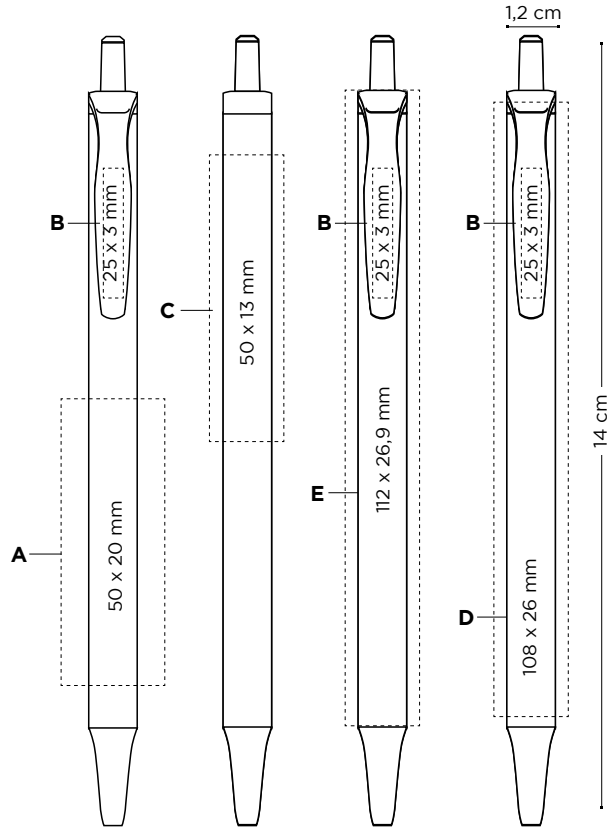

BIC® CLIC STIC
1000 / eColutions® 1E00

SP		
DG	①	①
1847		
SP	①	①
DG	①	①

① Prix sur demande.

Nouvel emballage spécial en option :



ECO Sleeve / Plastic Pouch

Emballage externe :



500 ± 2,9 Kg



FABRIQUÉ EN ESPAGNE

BIC® CLIC STIC SOFTFEEL®

1005

A/B SP: max. 1 col.

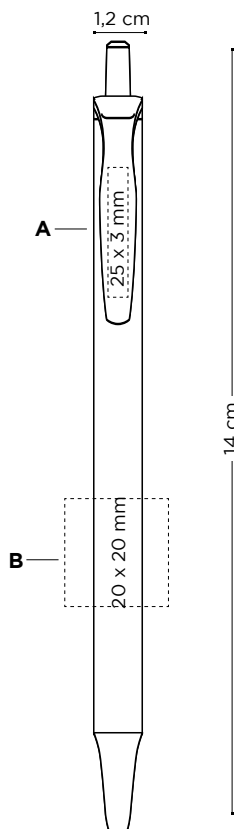

BIC® CLIC STIC MINI

1892

A SP: max. 1 col.

B SP: max. 1 col.

C DG: Numérique (zone texte)
(Disponible en corps blanc)

D DG: Numérique (zone image)
(Disponible en corps blanc)

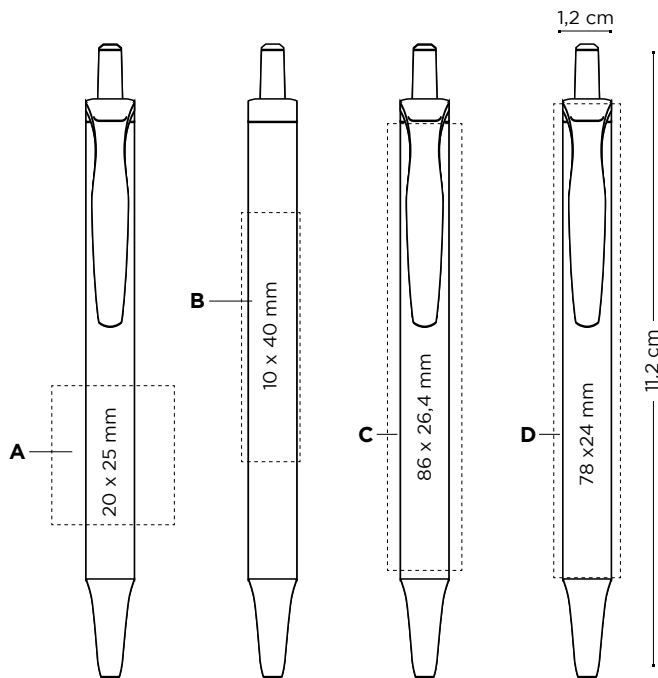

BIC® CLIC STIC SOFTFEEL®

1005

SP

SP

BIC® CLIC STIC MINI DIGITAL

1892

SP

DG

①

①

①

①

① Prix sur demande.

Nouvel emballage spécial en option :



ECO Sleeve / Plastic Pouch

+ INFO pag. 296

Emballage externe :



500 ± 2,9 Kg

Emballage externe :



500 ± 2,4 Kg





Design élégant et polyvalent, avec une grande variété de couleurs. De nombreuses possibilités de personnalisation avec sa zone d'impression XXL.





Opaque - 1039

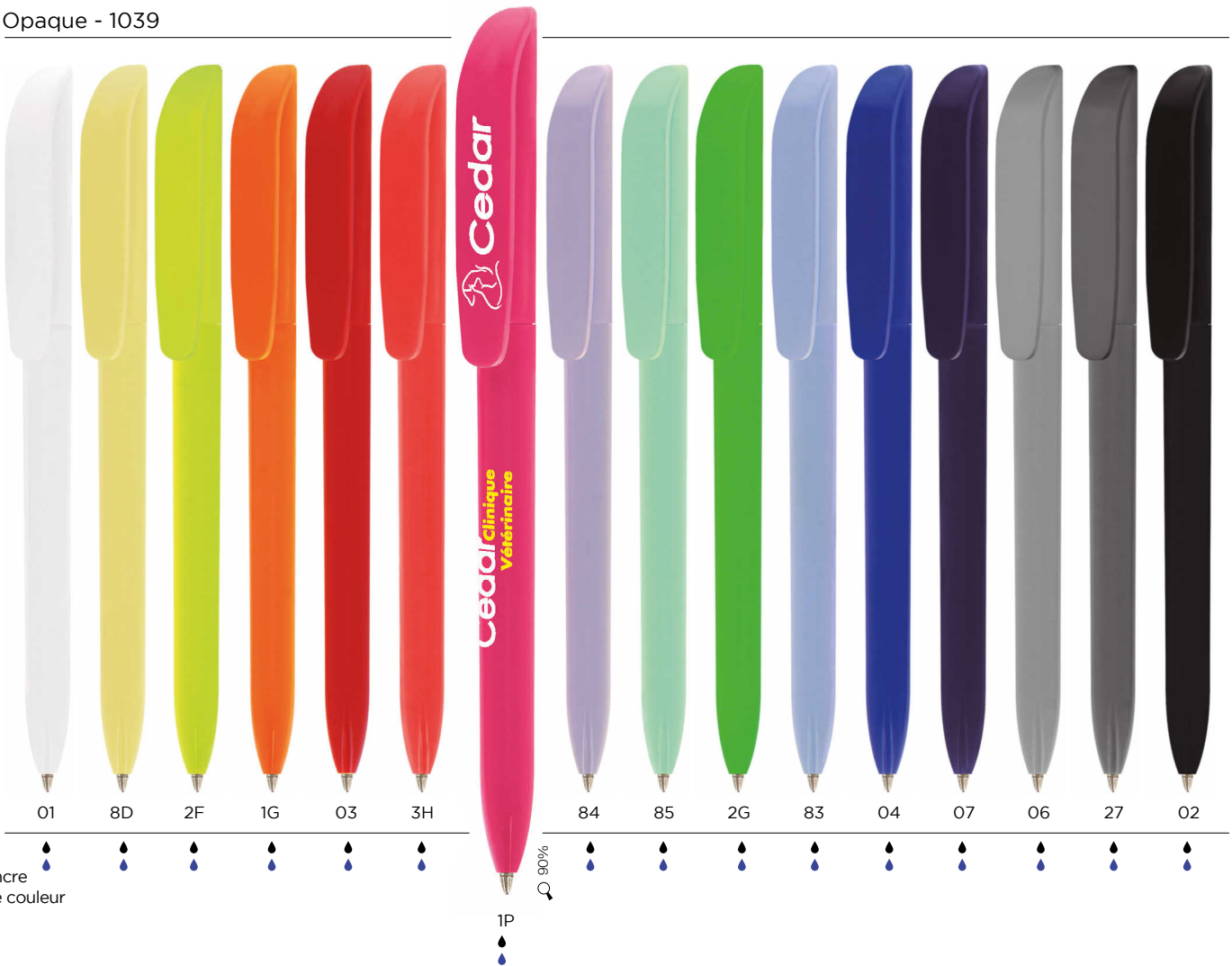

*48h non disponible en impression numérique



FABRIQUÉ À PARTIR
DE 83% DE MATÉRIEL
RECYCLÉ ET EST
100% RECYCLABLE

ecolutions®
Opaque
1E50



01/1E

*Pourcentage calculé sur le
poids total du corps du stylo

Transparent - 1039



51

92

87

95

93

88

86

89

90%

BIC® SUPER CLIP DIGITAL
Opaque - 1039

Impression
numérique!



01

01

90%

Uniquement disponible
en corps blanc



Commande minimale 250u.

Combinaison de couleurs standards

Clip



OPAQUE 01 8D 2F 1G 03 3H 1P 84 85 2G 83 04 07 06 27 02



TRANSPARENT 51 92 87 95 93 88 86 89

Combinaison de couleurs standards
ecolutions

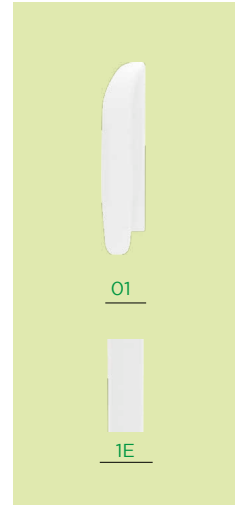

Ajoutez la boucle mobius sur votre BAT sans frais additionnel. Merci de le préciser dans votre bon de commande (en bas à gauche par défaut)

Corps



OPAQUE 01 8D 2F 1G 03 3H 1P 84 85 2G 83 04 07 06 27 02



TRANSPARENT 51 92 87 95 93 88 86 89

Injection d'une couleur spécifique :

≥ 10.000 unités

Mode d'écriture :

Techniques d'impression :

Nouvel emballage spécial en option :

Emballage externe :

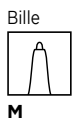

FABRIQUÉ EN ESPAGNE

+ INFO pag. 296

Personnalisation :

BIC® SUPER CLIP

1039

©©olutions® 1E50

A SP: max. 2 col.

B SP: max. 1 col.

C DG: Numérique

D BP: Quadrichromie

BP Texture: Quadrichromie

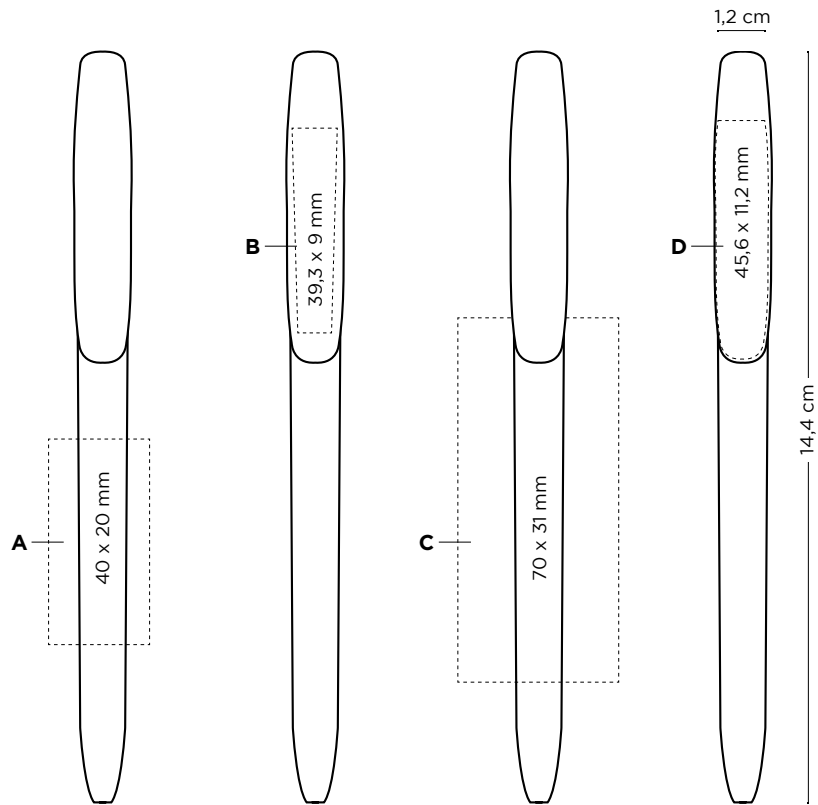

BIC® SUPER CLIP

1039 / ©©olutions® 1E50

SP

DG

BP



Opaque - 1073



*48h non disponible en impression numérique





Impression numérique!

BIC® SUPER CLIP ADVANCE DIGITAL
Opaque - 1073



Commande minimale 250u.

Combinaison de couleurs standards

Clip

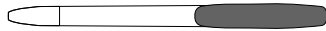

OPAQUE 01 2F 1G 03 3H 1P 2G 04 07 06 27 02



CLEAR 51 92 87 95 93 88 86 89

Corps



OPAQUE 01 2F 1G 03 3H 1P 2G 04 07 06 27 02

Section

ADVANCE



35

Injection d'une couleur spécifique :

≥ 10.000 unités



Mode d'écriture : Techniques d'impression :



M



(SP) SÉRIGRAPHIE



(DG) NUMÉRIQUE



(BP) britePix™



Nouvel emballage spécial en option :



ECO Sleeve / Plastic Pouch / Window Box

+ INFO pag. 296

Emballage externe :



500 ± 3,9 Kg

Regardez la video



FABRIQUÉ EN ESPAGNE

Personnalisation :

BIC® SUPER CLIP ADVANCE

1073

A SP: max. 2 col.

B SP: max. 1 col.

C DG: Numérique

D BP: Quadrichromie

BP Texture: Quadrichromie

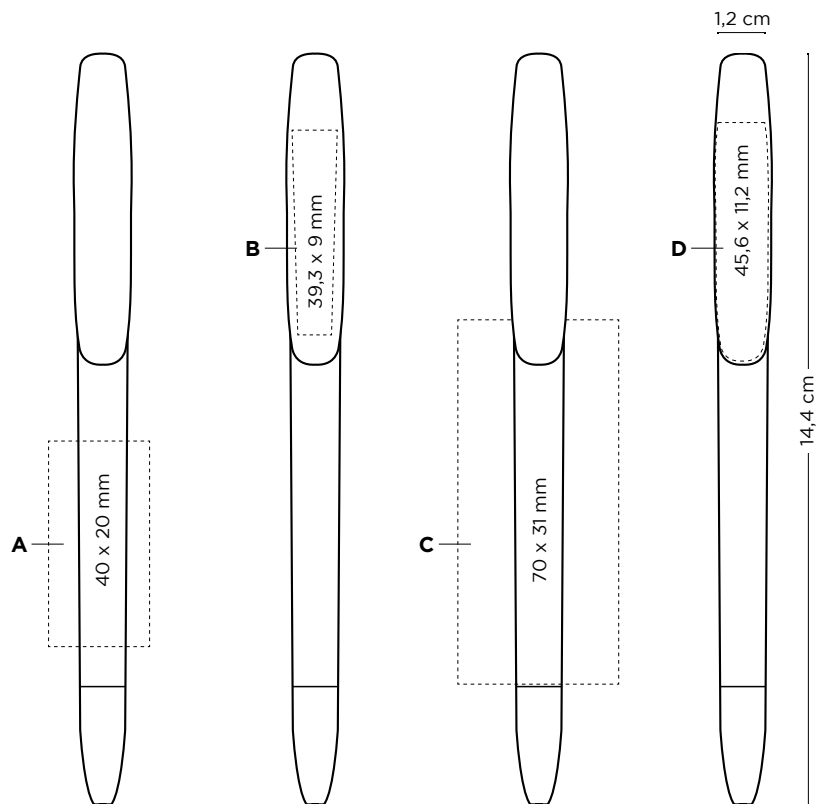



La taille idéale pour valoriser au mieux votre marque !
Corps large et multiples possibilités pour optimiser votre communication.







MIX & MATCH



l'icône BIC® BOY est en relief

Opaque - 1080



01

03

07

02

Encre de couleur

Encre rouge disponible sur demande

18



FABRIQUÉ À PARTIR DE 94% DE MATÉRIEL RECYCLÉ ET EST 100% RECYCLABLE

eco^lutions®
Opaque - 1E80



1E

*Pourcentage calculé sur le poids total du corps du stylo



**48h non disponible en impression numérique

Givré - 1080





BIC® WIDE BODY™ CHROME
Opaque - 1079

Givré - 1079

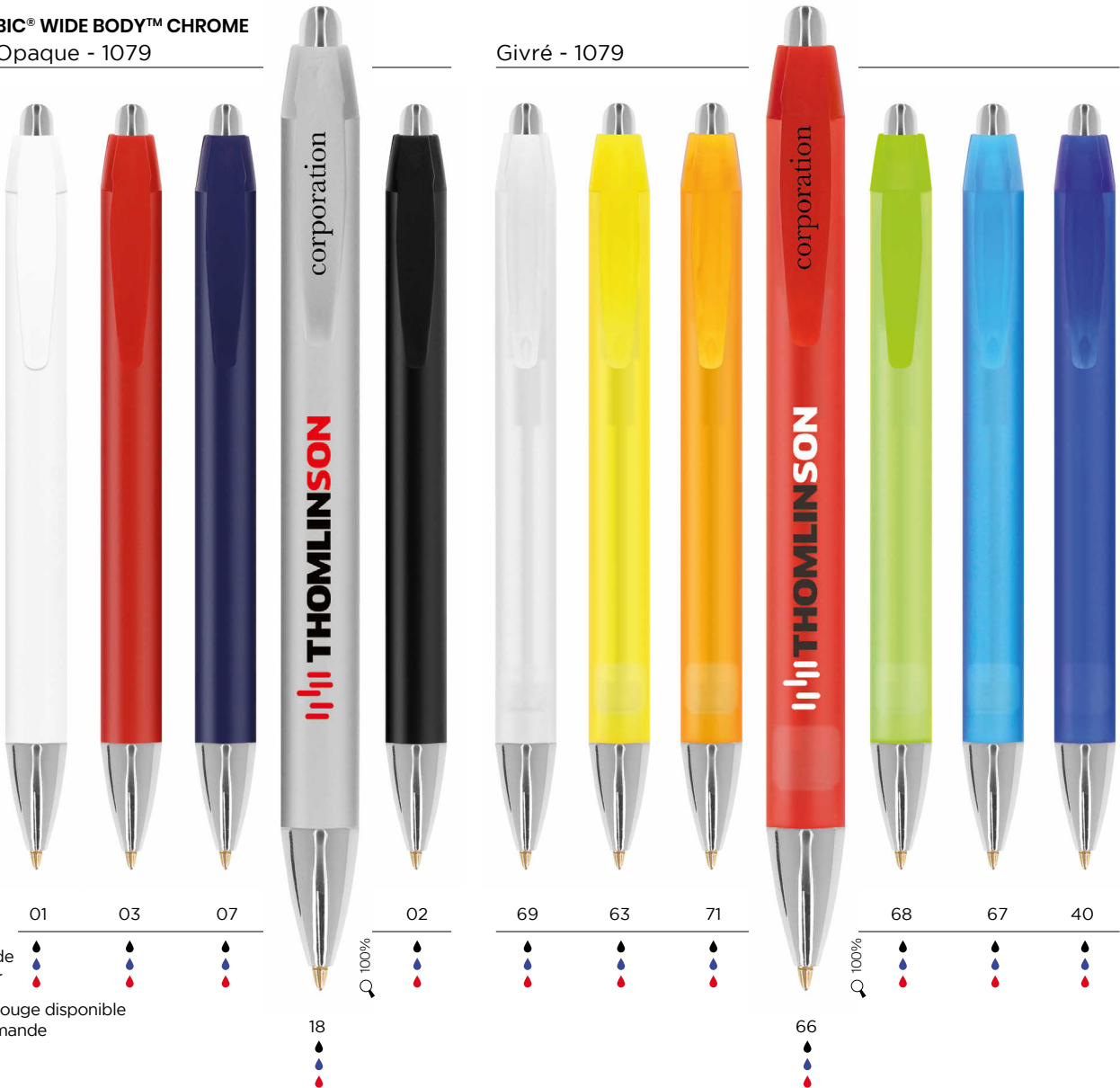

Encre de couleur

Encre rouge disponible sur demande

100%

100%

*48h non disponible en impression numérique



Impression numérique!

**BIC® WIDE BODY™
DIGITAL**
Opaque
1080 / 1E80

**BIC® WIDE BODY™
MINI DIGITAL**
Opaque - 1893



68



03



100%

Uniquement
disponible en
corps blanc

01



01



100%

Impression numérique!

**BIC® WIDE BODY™
CHROME DIGITAL**
Opaque - 1079

**BIC® WIDE BODY™
CHROME MINI DIGITAL**
Opaque - 1896



68



01



100%

01



01



100%



Commande minimale 250u.

Combinaison de couleurs standards

Bouton

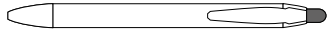

Chrome



Clip

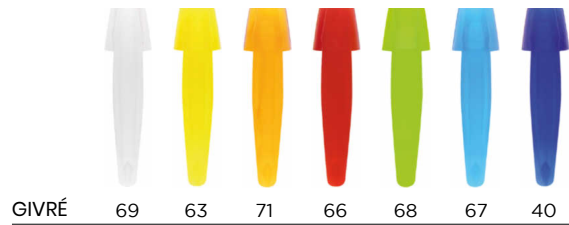
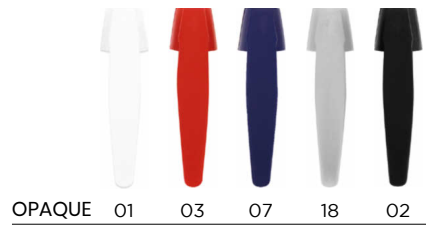
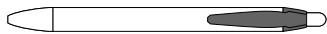

Corps

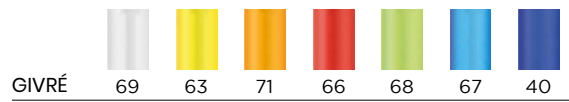
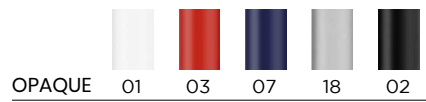

Section

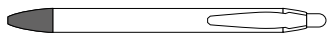

Injection d'une couleur spécifique :

≥ 10.000 unités

Mode d'écriture : Techniques d'impression :

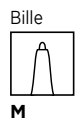

Commande minimale 250u.

Combinaison de couleurs standards **ecolutions®**

Bouton

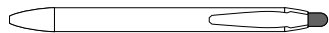

OPAQUE	01	03	07	18	02	GIVRÉ	69	63	71	66	68	67	40
--------	----	----	----	----	----	-------	----	----	----	----	----	----	----

Clip

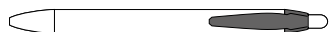

OPAQUE	01	03	07	18	02	GIVRÉ	69	63	71	66	68	67	40
--------	----	----	----	----	----	-------	----	----	----	----	----	----	----

Corps

OPAQUE **1E**



Ajoutez la boucle mobius sur votre BAT sans frais additionnel. Merci de le préciser dans votre bon de commande (en bas à gauche par défaut)

Section

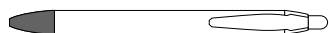

OPAQUE	01	03	07	18	02	GIVRÉ	69	63	71	66	68	67	40
--------	----	----	----	----	----	-------	----	----	----	----	----	----	----

Injection d'une couleur spécifique :

≥ 10.000 unités

Mode d'écriture :

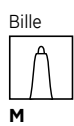

Techniques d'impression :



Personnalisation :

BIC® WIDE BODY™

1080

ECOolutions® 1E80

BIC® WIDE BODY™ CHROME

1079

A/C SP: max. 2 col.

B/F SP: max. 1 col.

D DG: Numérique (zone image)

E DG: Numérique (zone texte)

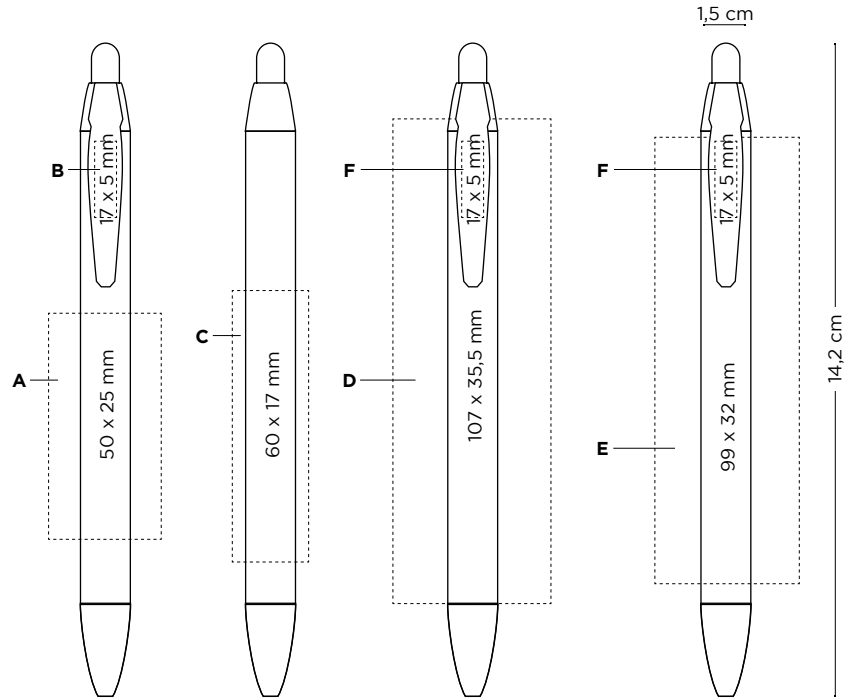

Nouvel emballage spécial en option :



ECO Sleeve / Plastic Pouch / Window Box

Emballage externe :



250 ± 2,6 Kg



FABRIQUÉ EN ESPAGNE

BIC® Wide Body™ mini Digital

1893

BIC® Wide Body™ mini Chrome Digital

1896

A DG: Numérique (zone image)

B DG: Numérique (zone texte)

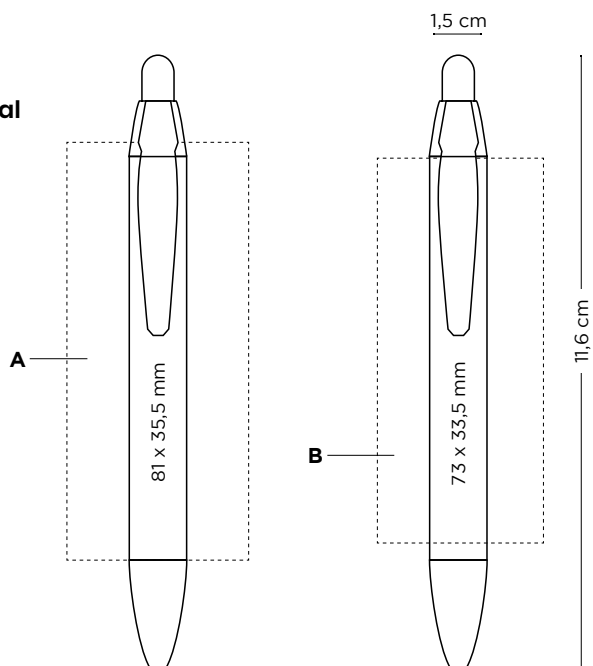

**Nouvel emballage spécial
en option :**



Plastic Pouch

**Emballage
externe :**



250 ± 1,9 Kg



**FABRIQUÉ EN
ESPAGNE**



Opaque - 1053

Transparent - 1053



l'icône BIC®
BOY est
en relief



07 02 01/03 01/05 01/07

Encre de couleur



01/02



51/07



51/02



Grip doux, très bonne prise en main

Commande minimale 250u.

Combinaison de couleurs standards

Personnalisation :

BIC® ATLANTIS®

1053

A PD: max. 1 col.

B/C SP: max. 2 col.

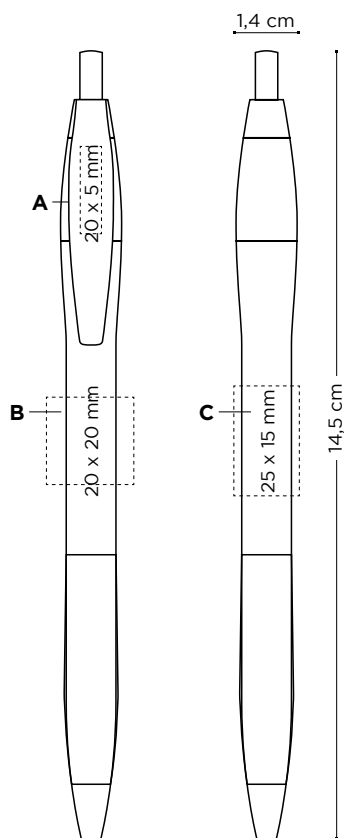

Mode d'écriture :

Bille



M

Techniques d'impression :



(SP)
SÉRIGRAPHIE



(PD)
TAMPOGRAPHIE

Nouvel emballage spécial en option :



ECO Sleeve / Plastic Pouch / Window Box

+ INFO pag. 296

Emballage externe :



250 ± 2,3 Kg





 **4 COLOURS**

Simple, fiable, ingénieux. Quatre couleurs d'encre différentes sur un seul stylo à bille : bleu, noir, rouge, vert. Un stylo emblématique toujours plus à la mode !

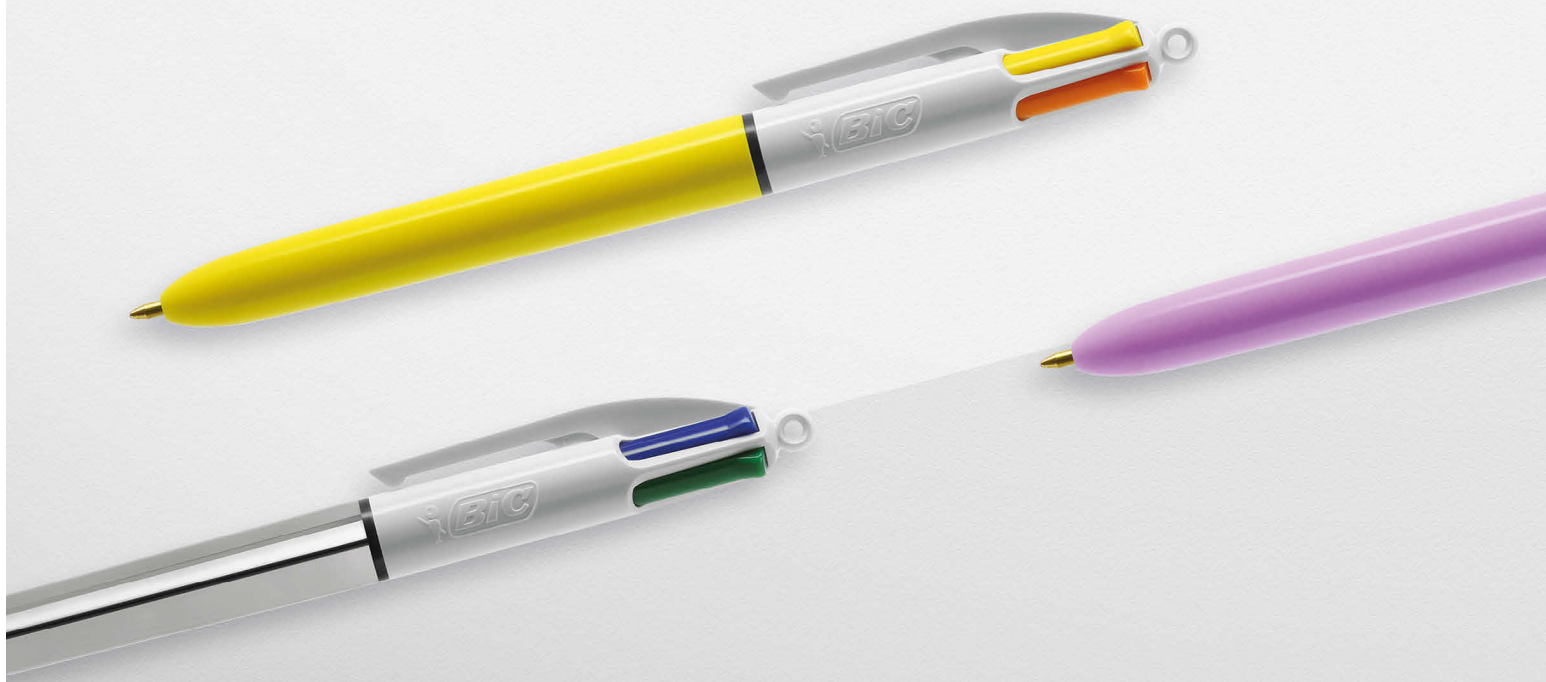

50
ans/years





Nouvelle technique pour
une communication en numérique

BIC Graphic Europe le pionnier du marquage en digital

Pour toute
couleur de
corps

Unlimited
and enhanced
colours

Haute
définition

360°



**GfK Panel - Western Europe 9 - MAT June 2018 - Sales in Value & Volume

BIC 4 COLOURS BRITEPIX™ DIGITAL *Nouveau !*

4 Colours - 1100

4 Colours Fashion - 1102

4 Colours Sun - 1097

4 Colours Fine - 1109



01/01 01/07 02/02



01/01 01/24 01/84 02/02

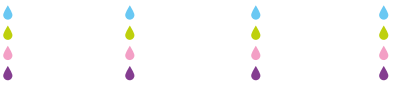

01/12 01/10



Encre de couleur

BIC® Instruments d'écriture • STYLOS



BIC® 4 COLOURS
 Opaque - 1100
 Avec tour de cou - 1101

Nouvelle couleur !



Encre de couleur

01/01

02/02

01/03

01/05

01/02

01/07

8.000 m d'écriture

*48h non disponible en impression numérique
 Disponible sans tour de cou

** Source: panel GFK - Western Europe 9 - MAT juin 2018 - Ventes en valeur et volume



MOQ 250u.

Personnalisation :

BIC® 4 COLOURS

1100

A SP: max. 4 col.

B DG: Digital print (zone image)

C BP: Numérique

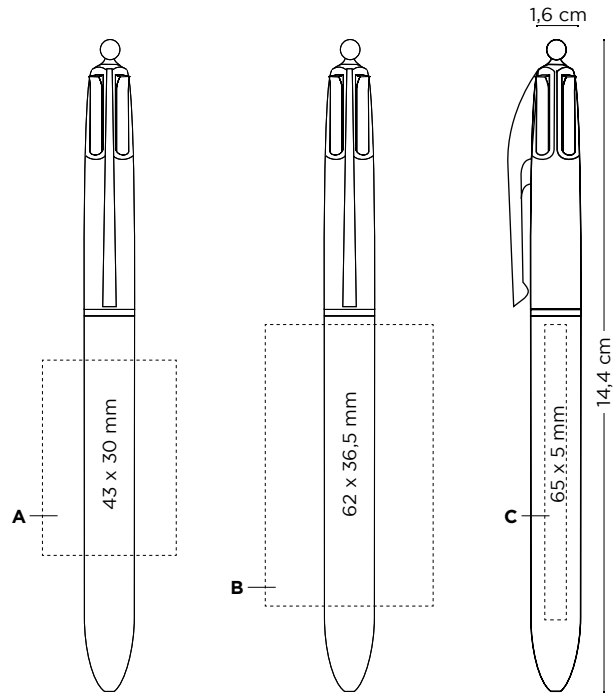

Mode d'écriture :

Bille



M

Techniques d'impression :



(SP)
SÉRIGRAPHIE



(BP) britePix™



Nouvel emballage spécial en option :



ECO Sleeve / Plastic Pouch / Window Box

+ INFO pag. 296

Emballage externe :



250 ± 3,2 Kg



Regardez la video



FABRIQUÉ EN FRANCE

www.bicgraphic.eu



BIC® 4 COLOURS MINI
 Opaque - 1103
 Avec tour de cou - 1104

Commande minimale 250u.

Personnalisation :

BIC® 4 COLOURS MINI
 1103
 D SP: max. 4 col.

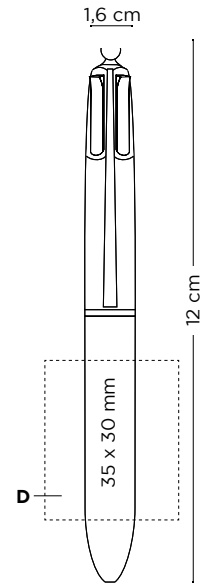

Mode d'écriture :



M

*48h non disponible en impression numérique
 Disponible sans tour de cou

Techniques d'impression :



(SP)
 SÉRIGRAPHIE

Emballage externe :



250 ± 2,7 Kg





BIC® 4 COLOURS SUN

Opaque - 1097

Avec tour de cou - 1098

2 new flashy colours: orange & yellow



MOQ 250u.

Personnalisation :

BIC® 4 COLOURS SUN

1097

A SP: max. 4 col.

B DG: Digital print (zone image)

C BP: Numérique

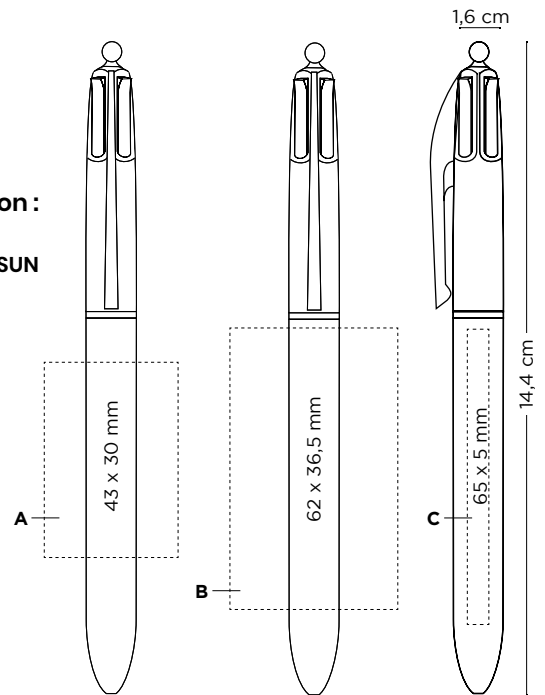

Mode d'écriture :

Bille



M

*48h non disponible en impression numérique
Disponible sans tour de cou

Techniques d'impression :



(SP) SÉRIGRAPHIE



(BP) britePix™



Nouvel emballage spécial en option :



ECO Sleeve / Plastic Pouch / Window Box

+ INFO pag. 296

Emballage externe :



250 ± 3,2 Kg



FABRIQUÉ EN FRANCE





Encres Fashion

BIC® 4 COLOURS FASHION
 Opaque - 1102
 Avec tour de cou - 1108



Encre de couleur

01/01

01/24

01/84

02/02



*48h non disponible en impression numérique
 Disponible sans tour de cou

MOQ 250u.

Personnalisation :

BIC® 4 COLOURS FASHION

1102

A SP: max. 4 col.

B DG: Digital print (zone image)

C BP: Numérique

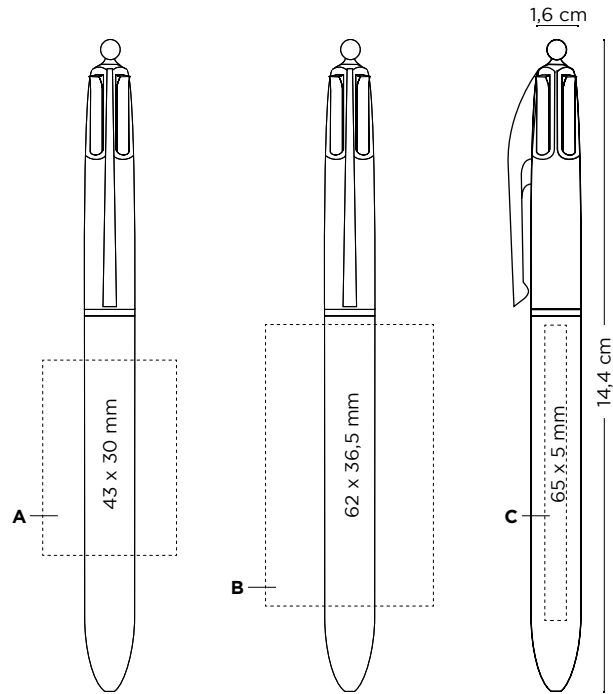

Mode d'écriture :

Bille



M

Techniques d'impression :



(SP)
SCREEN
PRINTING



(BP) britePix™



britePix
DIGITAL

Nouvel emballage spécial
en option :



ECO Sleeve / Plastic Pouch / Window Box

+ INFO pag. 296

Emballage
externe :



250 ± 3,2 Kg



MADE IN
FRANCE

www.bicgraphic.eu

91



BIC® 4 COLOURS SHINE
Opaque - 1106
Avec tour de cou - 1107



Corps super brillant!

01/75

01/26

01/34

Encre de couleur



01/7G



100%



Commande minimale 250u.

Personnalisation :

BIC® 4 COLOURS SHINE

1106

A SP: max. 2 col.

B LE

C LE

D LE 360°

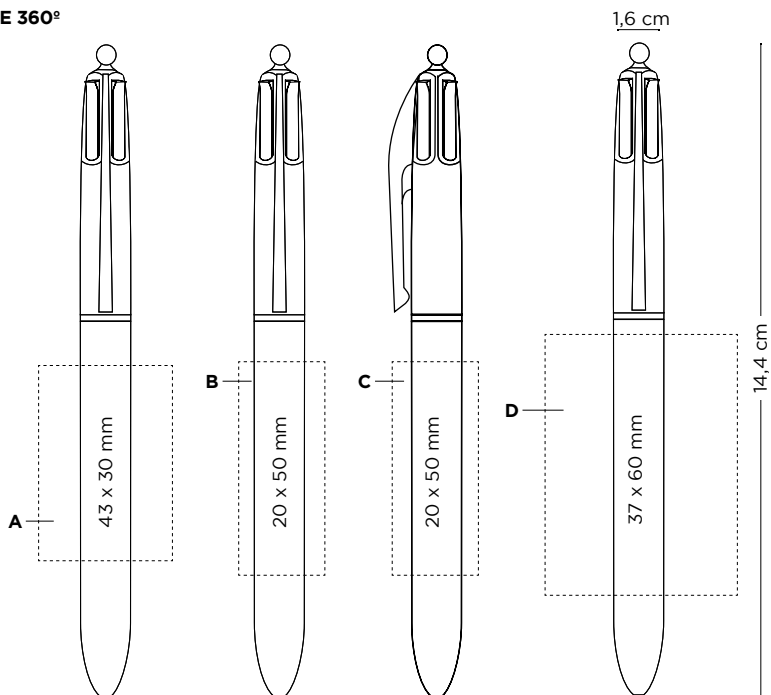

Mode d'écriture :



M

Techniques d'impression :



Nouvel emballage spécial en option :



ECO Sleeve / Plastic Pouch / Window Box

+ INFO pag. 296

Emballage externe :



250 ± 3,2 Kg



FABRIQUÉ EN FRANCE

www.bicgraphic.eu

93



BIC® 4 COLOURS FINE
 Opaque - 1109
 Avec Tour De Cou - 1111



MOQ 250u.

Personnalisation :

BIC® 4 COLOURS FINE
 1109
A SP: max. 4 col.
B DG: Digital print
C BP: Numérique

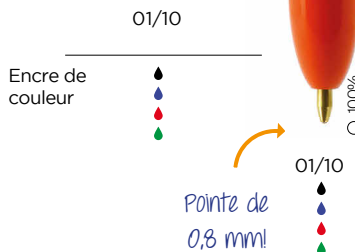
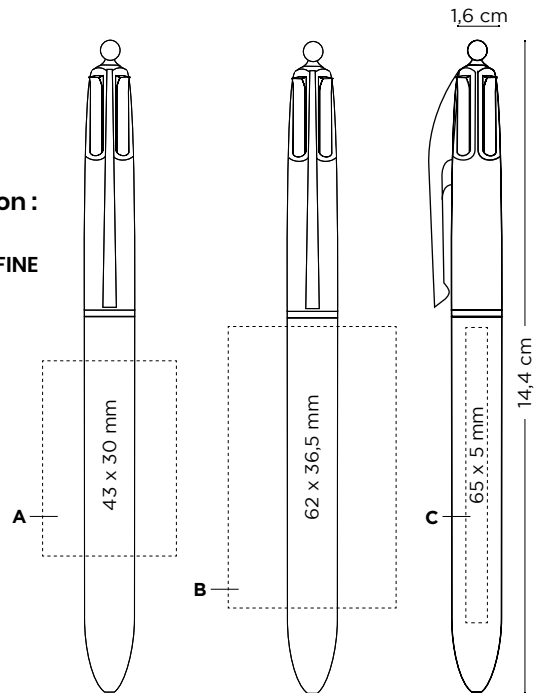

Mode d'écriture :



F
 *48h non disponible en impression numérique
 Disponible sans tour de cou

Techniques d'impression :



(SP) SCREEN PRINTING



(BP) britePix™



Nouvel emballage spécial en option :



ECO Sleeve / Plastic Pouch / Window Box

Emballage externe :



250 ± 3,2 Kg



FABRIQUÉ EN FRANCE





BIC® 4 COLOURS FLUO
 Opaque - 1114
 Avec Tour De Cou - 1116

Encre jaune fluo !



MOQ 250u.

Personnalisation :

BIC® 4 COLOURS FLUO

1114

A SP: max. 4 col.

B BP: Numérique

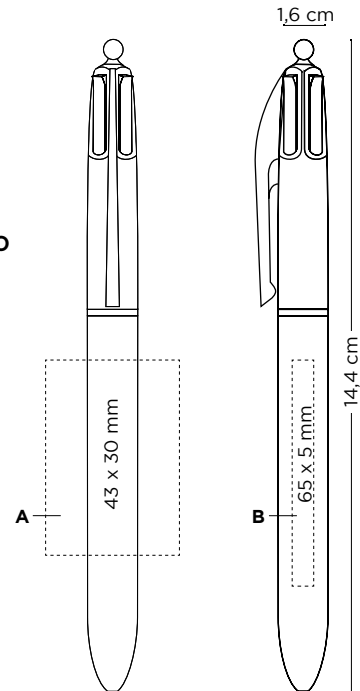

Mode d'écriture :

Ballpen



B

*48h non disponible en impression numérique
 Disponible sans tour de cou

Techniques d'impression :



(SP) SCREEN PRINTING



(BP) britePix™



Nouvel emballage spécial en option :



ECO Sleeve / Plastic Pouch / Window Box

+ INFO pag. 296

Emballage externe :



250 ± 3,2 Kg



FABRIQUÉ EN FRANCE





extrémité en caoutchouc pour écran tactile !

BIC® 4 COLOURS STYLUS
Opaque - 1112



02/02

Encre de couleur



02/02



Commande minimale 250u.

Personnalisation :

BIC® 4 COLOURS STYLUS

1112

A SP: max. 1 col.

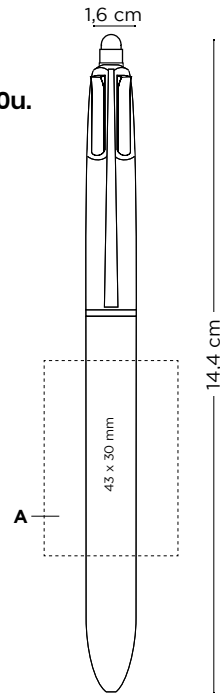

Mode d'écriture :

Bille



M

Techniques d'impression :



(SP)
SÉRIGRAPHIE

Nouvel emballage spécial en option :



Plastic Pouch
+ INFO pag. 296

External packaging:



250 ± 3,2 Kg





BIC® 4 COLOURS 3+1^{HB}
Opaque - 1099



01/06

Commande minimale 250u.

Personnalisation :

BIC® 4 COLOURS 3+1^{HB}
1099
A/B LE

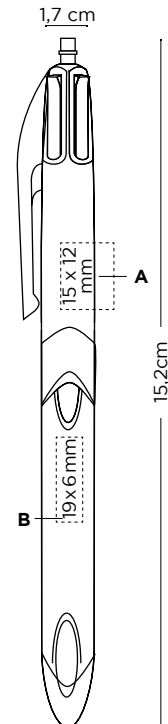

Encre de couleur



01/06

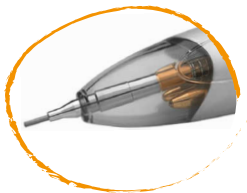

Mode d'écriture :

Techniques d'impression :

Nouvel emballage spécial en option :

External packaging:

Regardez la video

Bille & Porte-mine



M-MP
Ø0,7mm



(LE)
LASER



Plastic Pouch
+ INFO pag. 296



250 ± 3,5 Kg



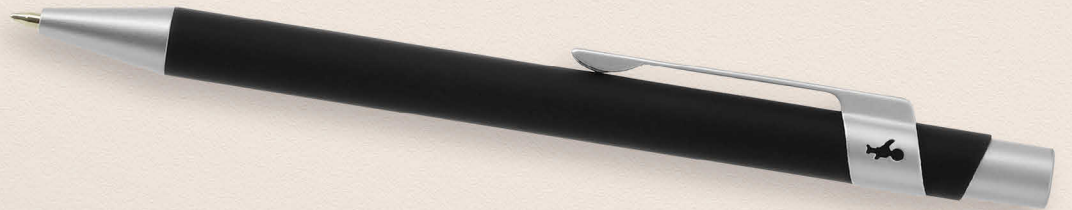



Détails métalliques, design moderne avec un grand choix de couleurs et de finitions. Confort d'écriture maximal, encre rechargeable allemande

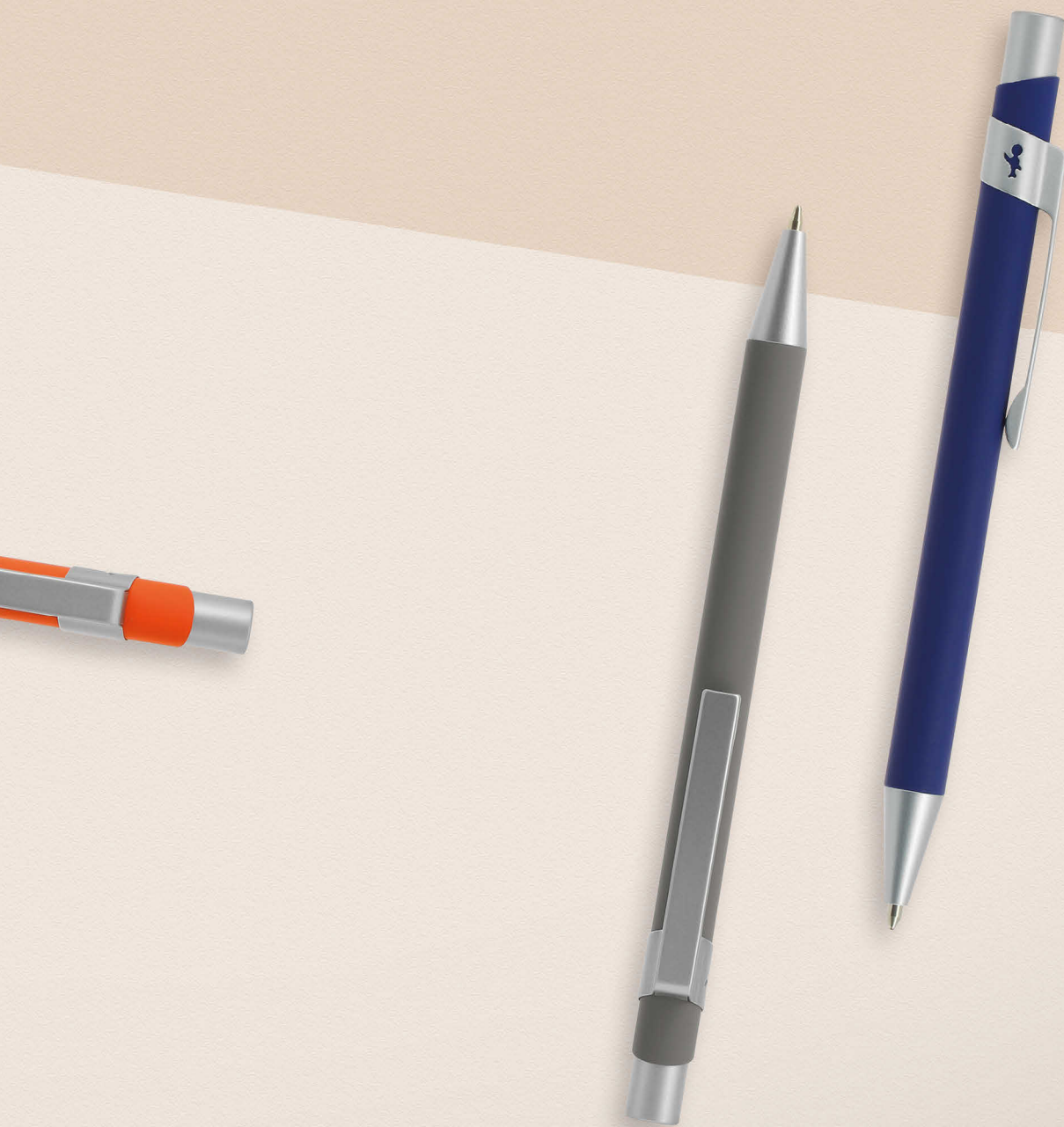

Nouveau !

Soft - 1290



01

10

03

04

08

02

05

Encre de couleur



Brillant -
1290



Nouveau !

Matte - 1290



Commande minimale 50u.

Personnalisation :

BIC® METAL PRO

1290

A SP: max. 2 col.

(Non disponible en finition soft)

B LE/SP: max. 1 col.

C LE 360°

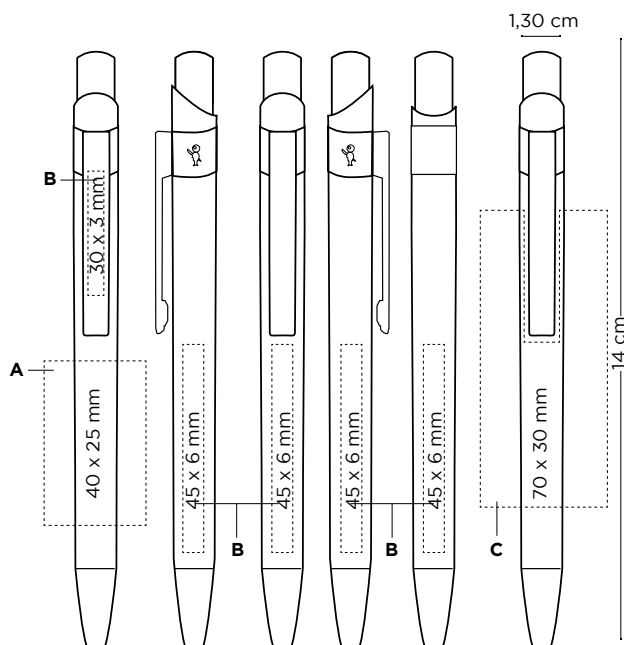

Mode d'écriture :



Techniques d'impression :



Nouvel emballage spécial en option :



Emballage externe :



 **GRIP ROLLER**

Profitez d'une expérience d'écriture fluide. Parfait pour les droitiers comme pour les gauchers, il glisse facilement sur le papier et ne fait pas de tâches grâce à son encre à séchage rapide.







stylo roller à encre liquide, pointe moyenne pour une écriture fluide et agréable

BIC® GRIP ROLLER 1187



Encre de couleur



Commande minimale 250u.

Personnalisation :

BIC® GRIP ROLLER

1187

A/B SP: max. 3 col.

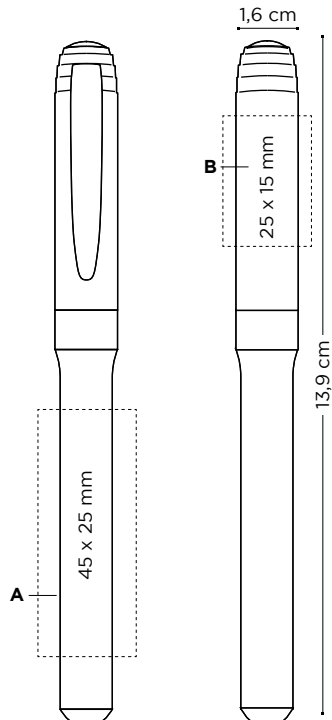

Mode d'écriture :

Roller



R
Ø0,7mm

Techniques d'impression :



(SP)
SÉRIGRAPHIE

Nouvel emballage spécial en option :



ECO Sleeve / Plastic Pouch / Window Box / Marking Set

+ INFO pag. 296 & 297

Emballage externe :



250 ± 3 Kg





Nouvelle couleur !
Nouvelle couleur !
Nouvelle couleur !

Opaque - 1851

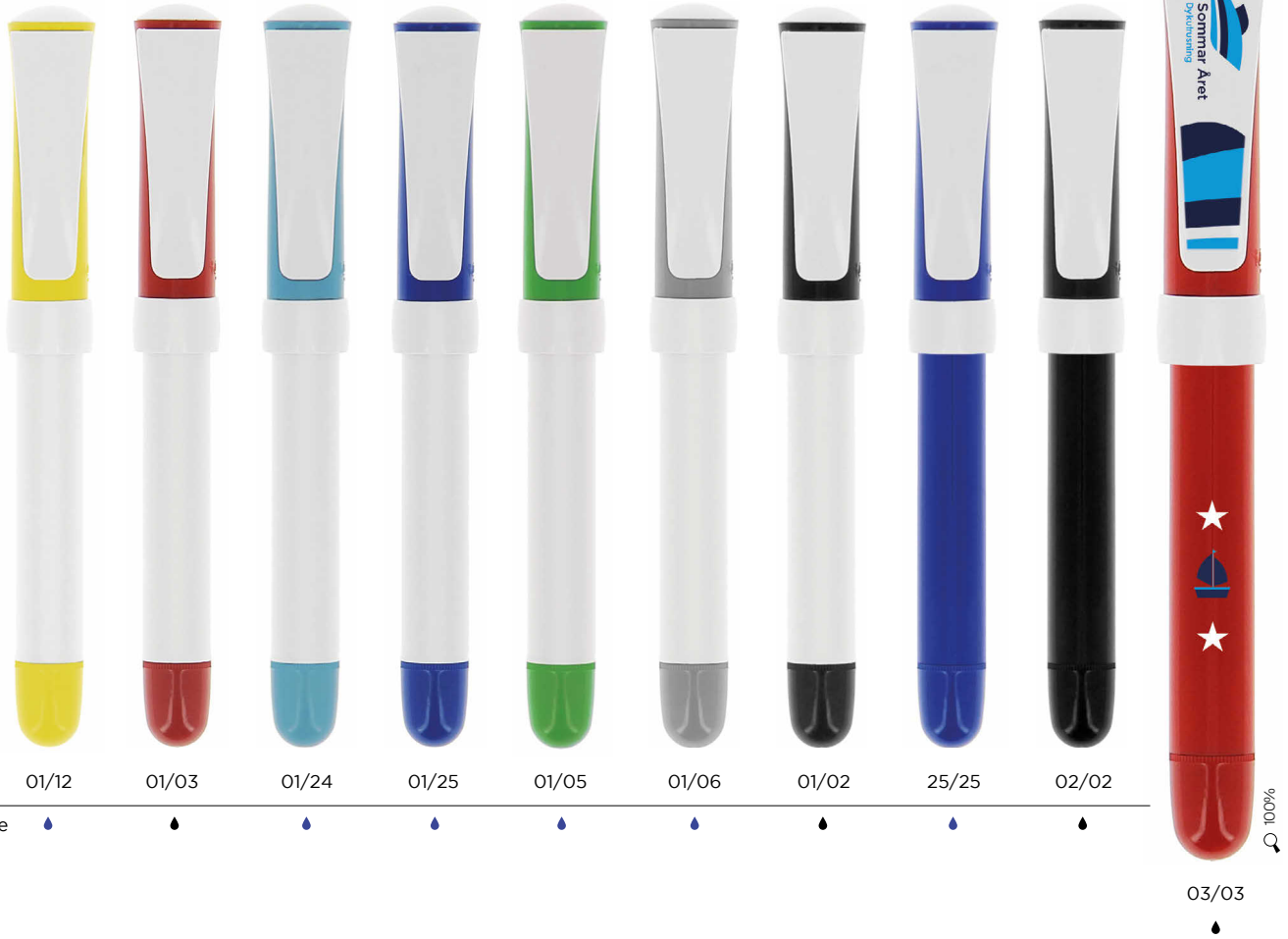

Encre de couleur

*48h not available for britePix™ decoration

Opaque /Transparent -
1851



Commande minimale 250u.

Personnalisation :

BIC® XS FINESTYLE

1851

A PD: max 2 col.

B SP: max 2 col.

C BP: Numérique

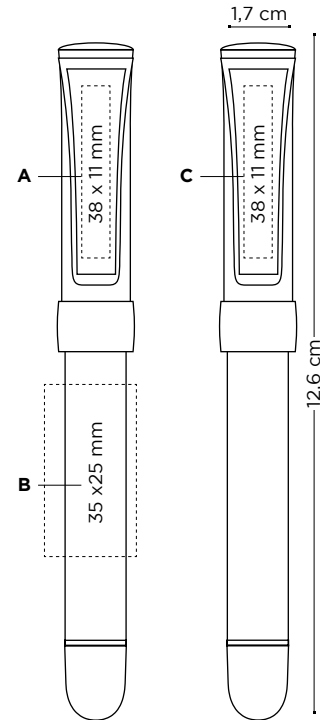

Injection d'une couleur spécifique :

≥ 10.000 unités

Mode d'écriture :

Pointe fine



FS
Ø0,7mm

Techniques d'impression :



(SP) SÉRIGRAPHIE



(PD) TAMOGRAPHIE



(BP) britePix™



Nouvel emballage spécial en option :



ECO Sleeve / Plastic Pouch

+ INFO pag. 296

Emballage externe :



250 ± 2,8 Kg



FABRIQUÉ EN
ESPAGNE



Vivez l'écriture en douceur avec les stylos à encre gel BIC®.
Il combine le confort et la souplesse pour une prise en
main agréable à l'heure d'écrire





l'icône BIC® BOY est en relief

1062



65

Encre de couleur



40

Commande minimale 250u.

Personnalisation :

BIC® ATLANTIS®GEL

1062

A PD: droite, gauche ou arrière clip max 1 col.

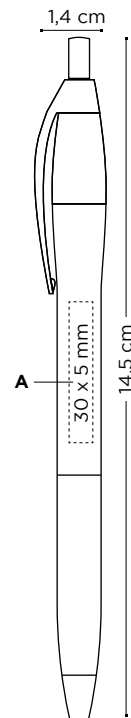

Mode d'écriture :

Techniques d'impression :

Nouvel emballage spécial en option :

Emballage externe :

Gel



G
Ø0,7mm

Jusqu'à épuisement du stock



(PD)
TAMPOGRAPHIE



ECO Sleeve / Plastic Pouch / Window Box



250 ± 3 Kg

+ INFO pag. 296



Opaque - 1136



03

Encre de couleur



05



04



02

se présente dans un carton individuel

Personnalisez-le sur mesure à partir de 500 unités



L'encre effaçable se base sur technologie thermosensible : écrivez, effacez et réécrivez encore

Nouveau !



Disponible uniquement en: UE (incluant la Norvège, la Suisse et la Turquie)

Commande minimale 250u.

Personnalisation :

BIC® GEL-OCITY® ILLUSION

1136

A SP: max. 1 col.

B DG: 4-colour process

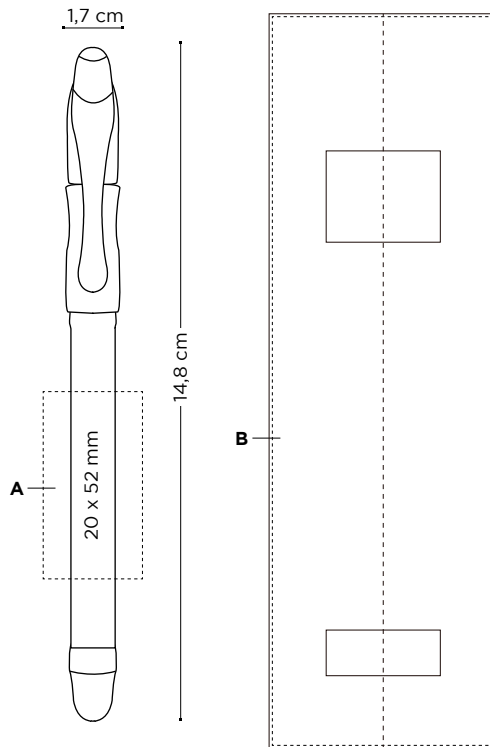

Mode d'écriture :

Gel effaçable



G
Ø0,7mm

Techniques d'impression :



(SP)
SÉRIGRAPHIE

Emballage externe :



500 ± 5,87 Kg



Opaque - 1196

Transparent - 1196

L'icône BIC® BOY est en relief



Encre de couleur

01

02

92

87

88

86

93



Commande minimale 250u.

Personnalisation :

BIC® INTENSITY® GEL CLIC

1196

A SP: max. 2 col.

B SP: max. 4 col.

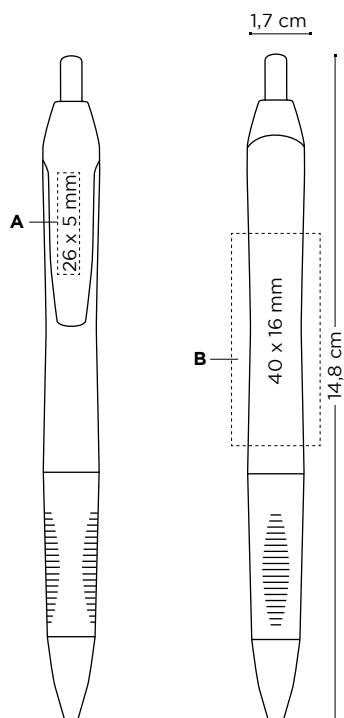

Mode d'écriture :

Gel



G
Ø0,7mm

Techniques d'impression :



(SP)
SÉRIGRAPHIE

Nouvel emballage spécial en option :



Plastic Pouch

+ INFO pag. 296

Emballage externe :



250 ± 3,7 Kg



Donnez de l'impact à votre message, de la précision et du contrôle à votre écriture, grâce au grip en caoutchouc.







Nouvelle couleur !
Nouvelle couleur !

1192

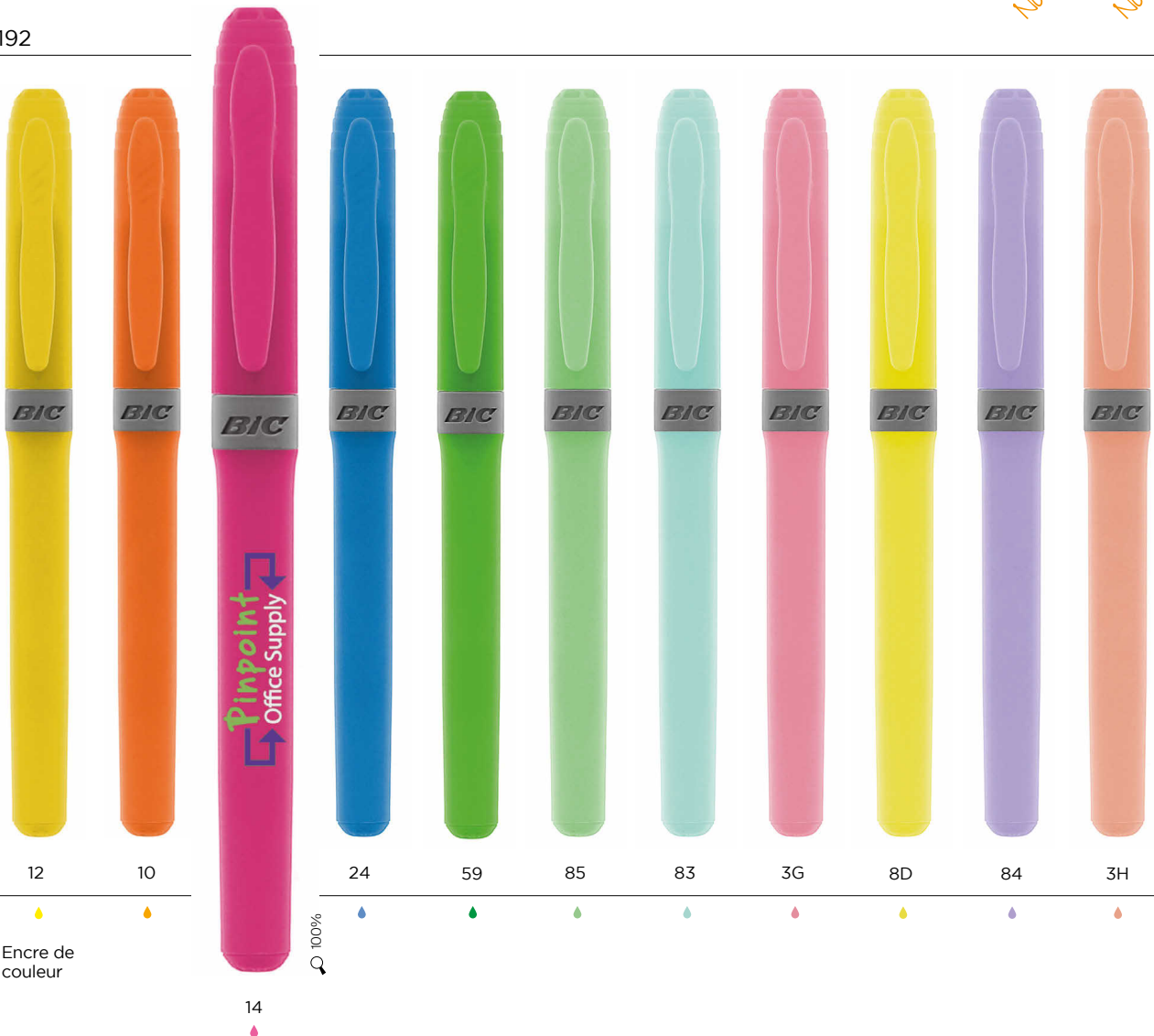

Encre de couleur

*Nouvelles couleurs disponibles en avril

Commande minimale 250u.

Personnalisation :

BIC® BRITE LINER® GRIP

1192

A/B SP: max. 3 col.

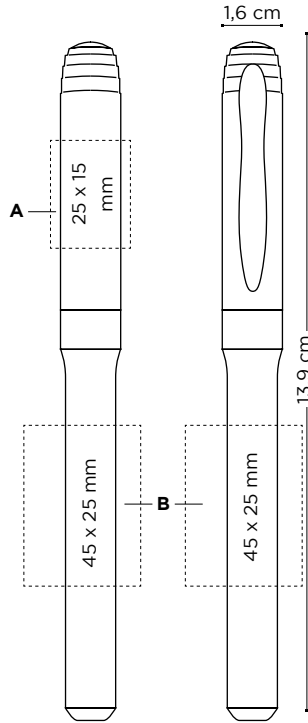

Mode d'écriture :

Highlighter



HL

Techniques d'impression :



(SP)
SCREEN
PRINTING

Maintenant disponible en set!

Nouvel emballage spécial
en option :



Marking Set

+ INFO pag. 297

Emballage externe :



250 ± 2,8 Kg





Les marqueurs BIC® sont des produits spécifiquement conçus pour écrire avec une haute visibilité, et sur des surfaces ou des matériaux sur lesquels d'autres instruments d'écriture ne peuvent être utilisés. Donnez de la visibilité à vos idées et exprimez-vous sur n'importe quelle surface avec les marqueurs BIC®.





1651



01/03

01/04

01/02

Encre de couleur



01/05



Commande minimale 500u.

Personnalisation :

BIC® Velleda® WHITE BOARD MARKER FINE

1651

A SP: max. 1 col.

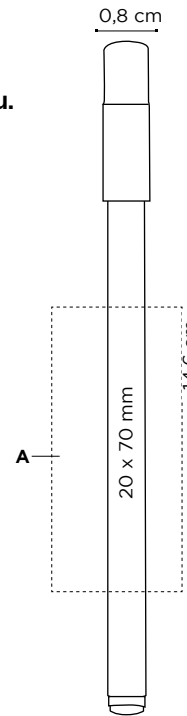

Mode d'écriture :

Techniques d'impression :

Maintenant disponible en set!

Nouvel emballage spécial en option :

Emballage externe :

Marqueur



MK



(SP) SÉRIGRAPHIE



Marking Set
+ INFO pag. 287



500 ± 3,2 Kg



FABRIQUÉ EN FRANCE



1213



01/03

01/05

01/04

Encre de couleur



01/02

100%

Commande minimale 250u.

Personnalisation :

BIC® Velleda® WHITE BOARD MARKER GRIP
1213
A/B SP: max. 3 col.

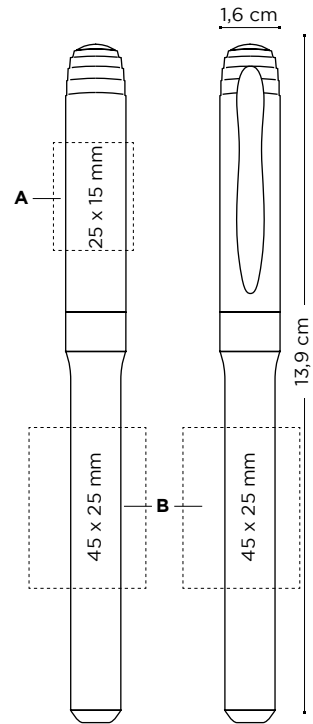

Mode d'écriture :

Marqueur pour ardoise blanche



MK

Printing techniques:



(SP) SÉRIGRAPHIE

Maintenant disponible en set!

Nouvel emballage spécial en option :



Marking Set

+ INFO pag. 297

External packaging:



250 ± 2,7 Kg



1214



Encre de couleur

100%

Commande minimale 250u.

Personnalisation :

**BIC® MARK-IT
PERMANENT MARKER**
1214
A/B SP: max. 3 col.

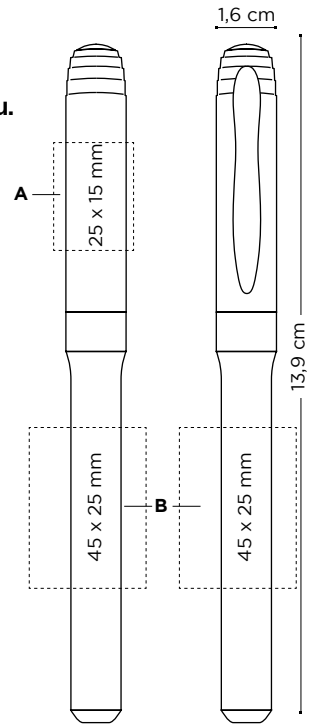

Maintenant disponible en set!

Mode d'écriture :

Techniques d'impression :

Nouvel emballage spécial en option :

Emballage externe :

Marqueur



MK



(SP)
SÉRIGRAPHIE



Marking Set
+ INFO pag. 297



250 ± 2,8 Kg



FABRIQUÉ À PARTIR DE 51% DE MATÉRIEL RECYCLÉ ET EST 100% RECYCLABLE



Ajoutez la boucle mobius sur votre BAT sans frais additionnel. Merci de le préciser dans votre bon de commande (en bas à gauche par défaut)

1210



Commande minimale 250u.

Personnalisation :

BIC PERMANENT MARKER **ecolutions**

1210

A SP: max. 1 col.

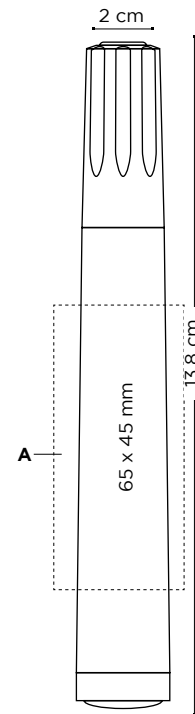

ecolutions Fabriqué avec 51% de matériaux recyclés.

Encre de couleur

02

100%

02

Mode d'écriture :

Printing techniques:

External packaging:

Marqueur



MK



(SP)
SÉRIGRAPHIE



250 ± 2,6 Kg



FABRIQUÉ EN FRANCE

*Le pourcentage est calculé sur le poids total du produit hors cartouche



Toujours prêt avec ce porte-mine de grande qualité. Il est solide et la mine est résistante. Il n'a pas besoin d'être taillé et offre une écriture plus fluide et plus intense que jamais !

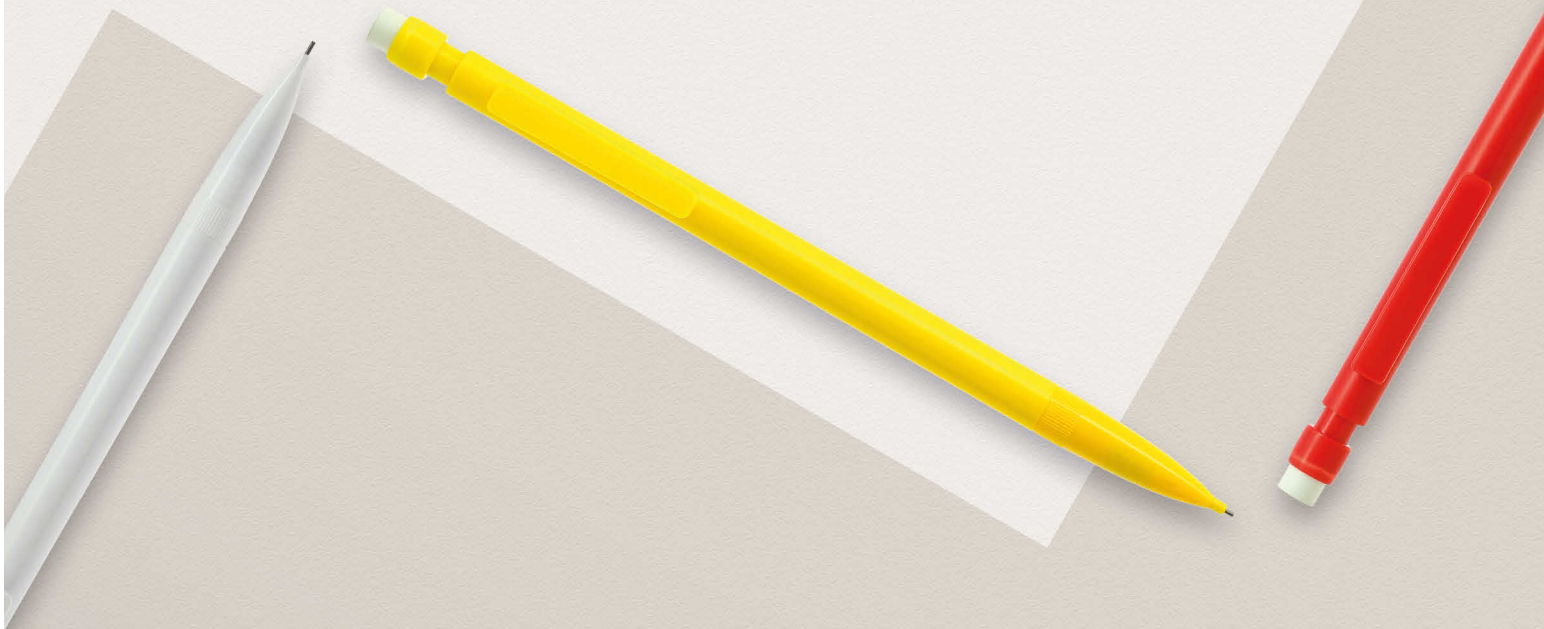





BIC® MATIC®
Opaque - 1120



BIC® MATIC®
eColutions®
Opaque - 1E40



FABRIQUÉ À PARTIR DE 65%
DE MATÉRIEL RECYCLÉ ET
EST 100% RECYCLABLE



01/01



12/12



03/03



59/8C



04/8C



07/07



06/8C



02/02

*Pourcentage calculé sur le poids
total du produit



Ajoutez la boucle mobius sur votre BAT
sans frais additionnel. Merci de le préciser
dans votre bon de commande (en bas à
gauche par défaut)



BIC® MATIC® QUARTZ
Opaque - 1121



51/01



51/03



51/04

100%



51/07

BIC® MATIC® QUARTZ METALLIC



51/18

BIC® MATIC® GRIP
Opaque - 1122



01/04



01/02



02/02

100%

BIC® MATIC® GRIP METALLIC



1D/02

* Jusqu'à épuisement du stock

Commande minimale 500u.

Personnalisation :

BIC® MATIC®
1120
eColutions® 1E40

BIC® MATIC®
QUARTZ & METALLIC
1121

A SP: max. 1 col. (non
disponible pour BIC® Matic®
Quartz)

B/C SP: max. 2 col.

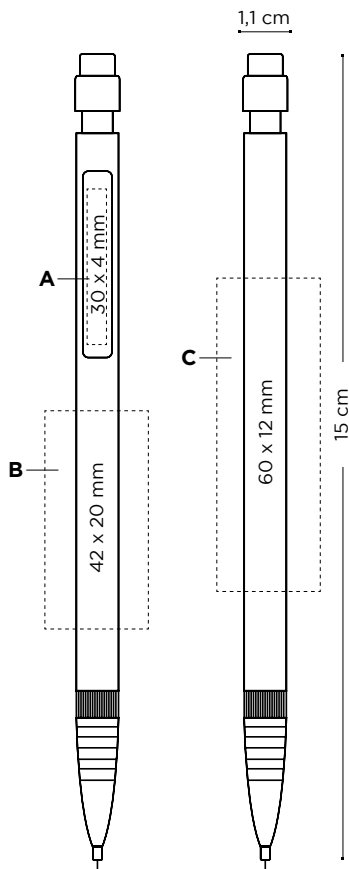

BIC® MATIC® GRIP
& METALLIC

1122

A SP: max. 1 col.

B/C SP: max. 2 col.

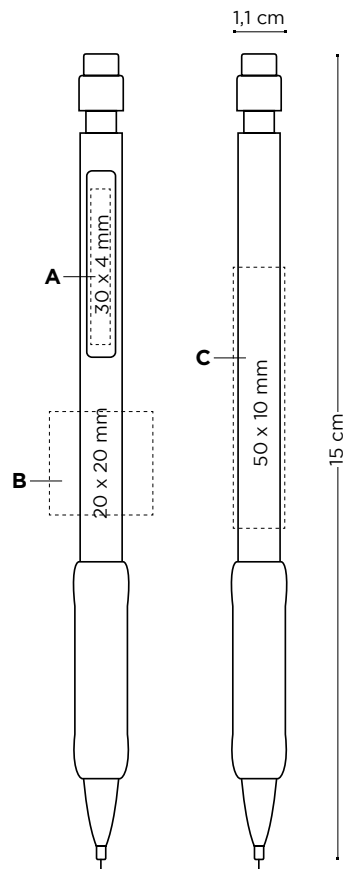

Mode d'écriture :

porte-mine



MP
Ø0,7mm

Techniques d'impression :



(SP)
SÉRIGRAPHIE

Nouvel emballage spécial
en option :



ECO Sleeve / Plastic Pouch

+ INFO pag. 296

Emballage
externe :



500 ± 3,1 Kg



FABRIQUÉ
EN FRANCE

Crayon papier en résine synthétique, sans bois, qui ne fait pas d'écharde en cas de casse. Mine graphite HB ultra-résistante qui s'efface facilement !





FABRIQUÉ À PARTIR DE 54% DE MATÉRIEL* RECYCLÉ ET EST 100% RECYCLABLE



FABRIQUÉ À PARTIR DE 46% DE MATÉRIEL* RECYCLÉ ET EST 100% RECYCLABLE



Crayon Avec Bout Coupe
1150

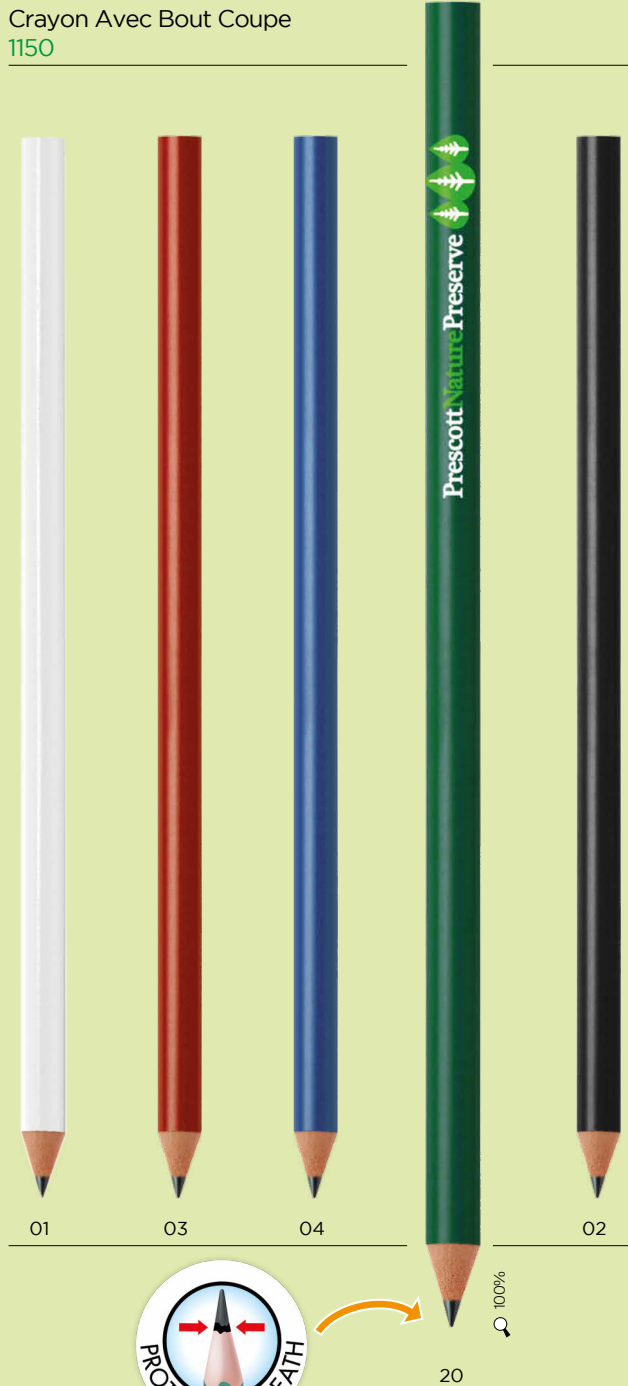

Crayon Avec Gomme
1151

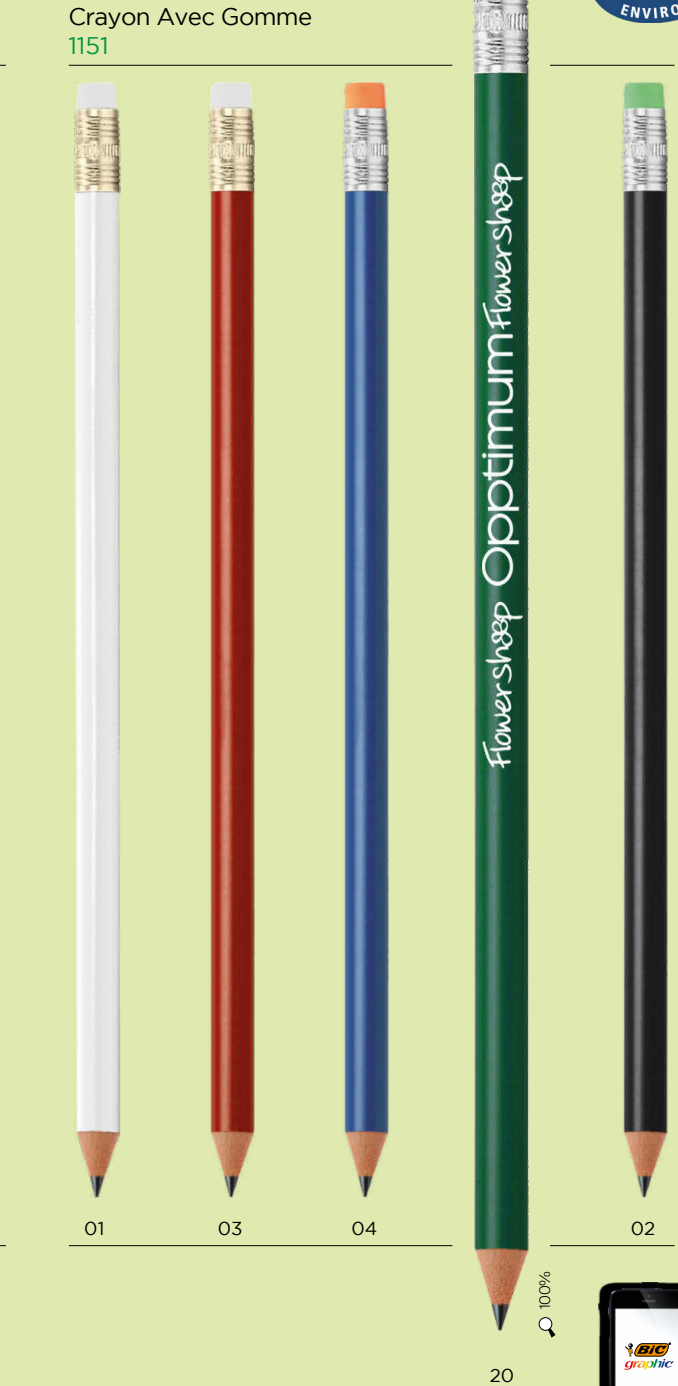

*Pourcentage calculé sur le poids total du produit

Impression numérique!



FABRIQUÉ À PARTIR DE 54%
DE MATÉRIEL* RECYCLÉ ET
EST **100% RECYCLABLE**

DIGITAL
Crayon
Papier 1150



01



METALLIC DIGITAL
Crayon
Papier 1962



47



FABRIQUÉ À PARTIR DE 46%
DE MATÉRIEL* RECYCLÉ ET
EST **100% RECYCLABLE**

DIGITAL
Crayon Papier
avec Gomme - 1151



01



METALLIC DIGITAL
Crayon Papier
avec Gomme - 1960



47



*Pourcentage calculé sur le poids total du produit

Commande minimale 500u.

**MIX &
MATCH**



Combinaison de couleurs standards

Gomme

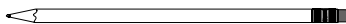

OPAQUE 01 COLOUR CONNECTION 01 12 10 14 59 07 02

Virole



OPAQUE 47 26 2C 34 02

Corps



OPAQUE 01 03 04 20 02

Métallique

OPAQUE 47 26

CRAYON PAPIER BOUT COUPÉ:

**FABRIQUÉ À PARTIR
DE 54% DE MATÉRIEL*
RECYCLÉ ET EST 100%
RECYCLABLE**



Ajoutez la boucle mobius sur votre BAT sans frais additionnel. Merci de le préciser dans votre bon de commande (en bas à gauche par défaut)

Mode d'écriture :



PC
HB Ø 2,3mm

Techniques d'impression :



(SP)
SÉRIGRAPHIE



(DG)
NUMÉRIQUE

Nouvel emballage spécial
en option :



Plastic Pouch
(x3 units)
+ INFO pag. 296

Emballage externe :



500 ± 3,5 Kg



FABRIQUÉ
EN FRANCE

BIC[®] EVOLUTION[®] eCOlutions[®]
 CRAYON BOUT COUPÉ
 1150

BIC[®] EVOLUTION[®]
 eCOlutions[®]
 CRAYON AVEC GOMME
 1151

A SP: max. 2 col.
B SP: max. 1 col.

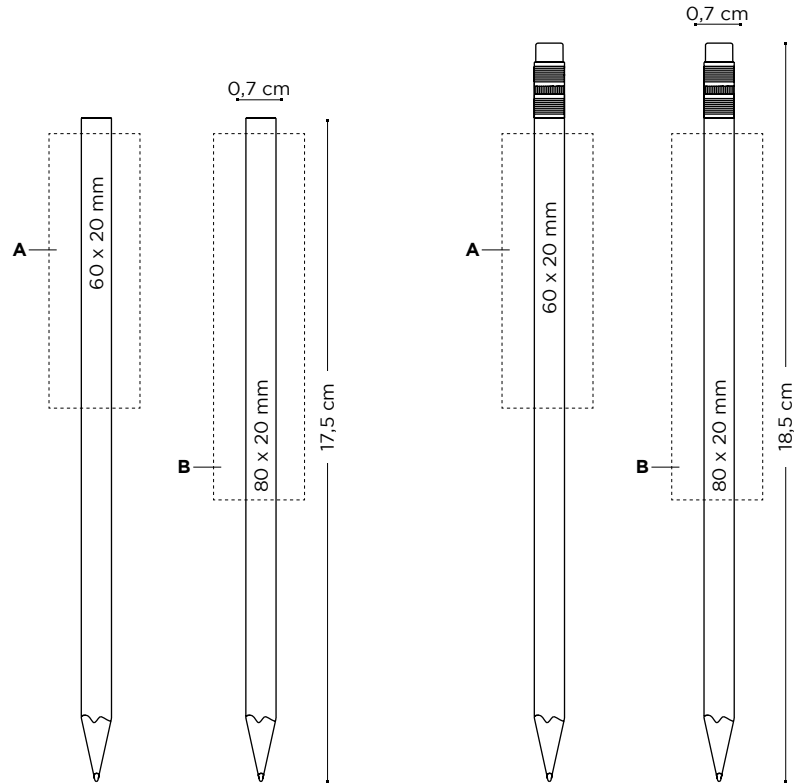

Emballage externe :



500 ± 3,5 Kg



FABRIQUÉ
 EN FRANCE

BIC® EVOLUTION® eColutions®
 CRAYON BOUT COUPE
 1150 Digital
 1962 Metallic Digital

BIC® EVOLUTION® eColutions®
 CRAYON AVEC GOMME
 IMPRESSION NUMERIQUE
 1151
 CRAYON AVEC GOMME IMPRESSION
 NUMERIQUE FINITION METALLIQUE
 1960

A DG: Numérique (zone image)
B DG: Numérique (zone texte)

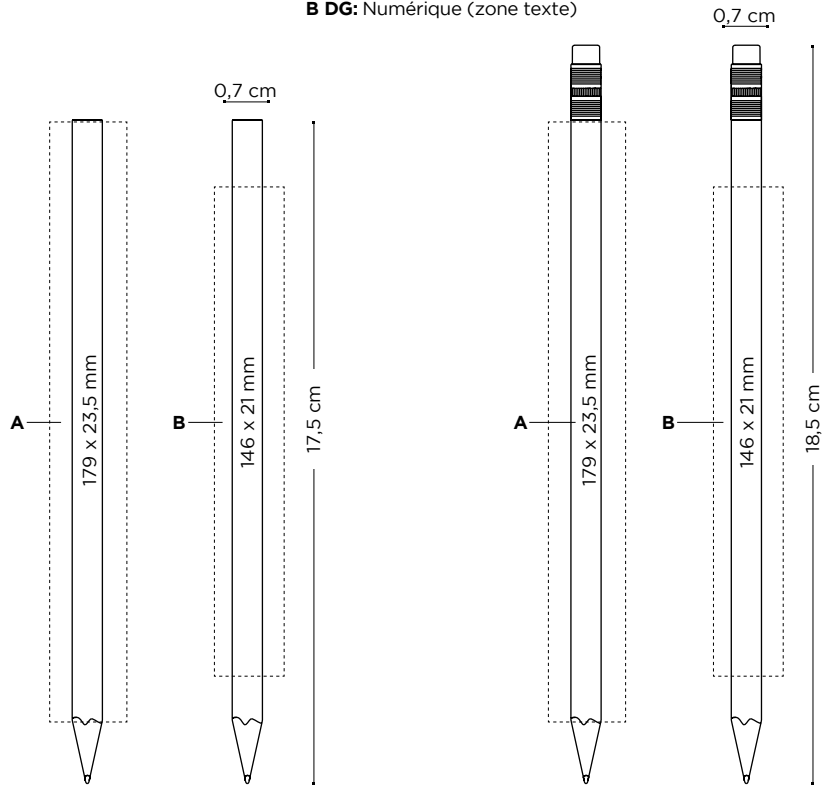

Maintenant disponible en set!

Nouvel emballage spécial en option : Emballage externe :



Plastic Pouch
 x3 units
 + INFO pag. 296



500 ± 3,5 Kg

1151/1150/1960



500 ± 2,6 Kg

1962



FABRIQUÉ
 EN FRANCE



Sprouts®



Les crayons Sprout personnalisables sont utilisés par les entreprises et les organisations du monde entier pour communiquer leur respect de l'environnement. Une fois que le crayon est trop court pour écrire, plantez-le et regardez votre message se transformer en superbe pot d'herbes aromatiques, de fleurs ou de légumes.



Combinez ces options!

1. Choisissez entre les graines différentes
2. Personnalisez votre crayon
3. Ajoutez le carton avec le mode d'emploi

53062

carton standard

carton personnalisable



Corps standard



Corps personnalisé



Emballage carton standard



back



Emballage carton personnalisé

80%

Sprouta MULTI COLOURED PENCIL



Nouveauté!

1 crayon pour plante - 4 couleurs!

1. Choisissez entre les graines différentes
2. Personnalisez votre crayon
3. Ajoutez le carton avec le mode d'emploi

carton standard

carton personnalisable!

53070



Corps standard



Corps personnalisé



Emballage carton standard



back

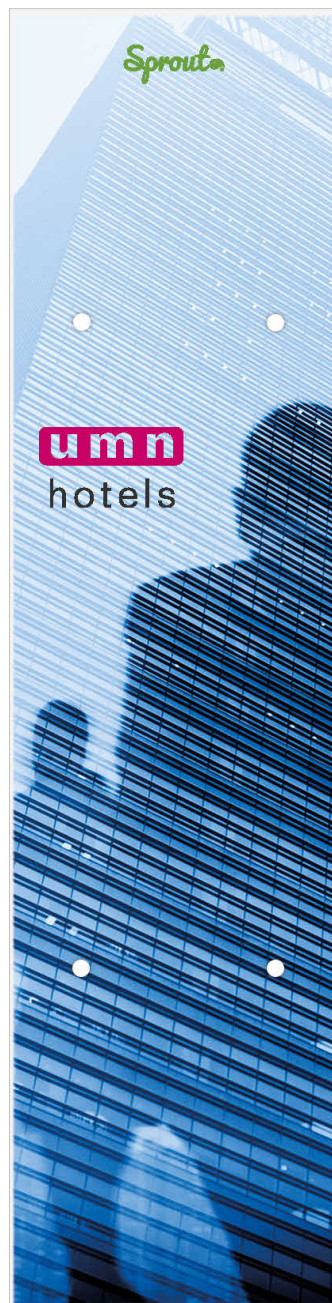

Emballage carton personnalisé



Quantité minimum de marquage: 500
 Quantité minimum de marquage: 1.000 (crayon + emballage carton personnalisé)

Personnalisation :

SPROUT™ PENCIL

53062 / 53070
A LE
B DG: 4-colour process

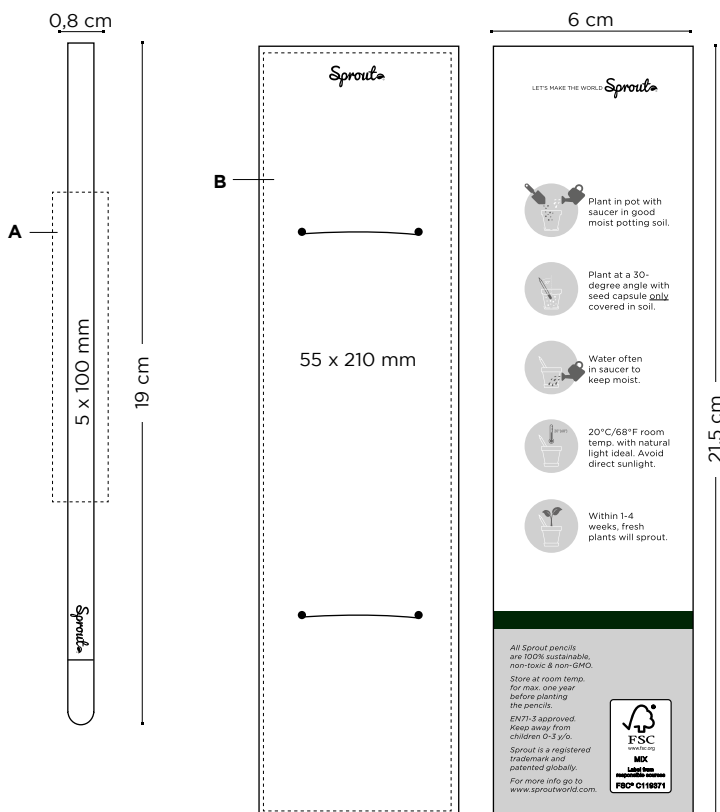

Mode d'emploi inclus au dos
 Pour un carton personnalisé, vous pouvez changer la police et les couleurs

Mode d'écriture :

Techniques d'impression :

Emballage externe :

Emballage :

Regardez la video



PC
 HB Ø 2,3mm



(DG)
 NUMÉRIQUE



(LE)
 LASER



500 ± 2,5 Kg Seulement crayon
 ± 5 Kg avec emballage en carton



 **COLORIAGE**

Set de 6 crayons aux couleurs vives sous les célèbres marques BIC® : PLASTIDECOR®, EVOLUTION® et VISA®. Présenté dans une pochette carton totalement personnalisable. Un article de promotion idéal pour les enfants et les ados !







Colouring crayons 1201



Commande minimale 500u.

Personnalisation :

BIC® PLASTIDECOR®
LOT DE 6 CRAIES

1201

A DG: Numérique

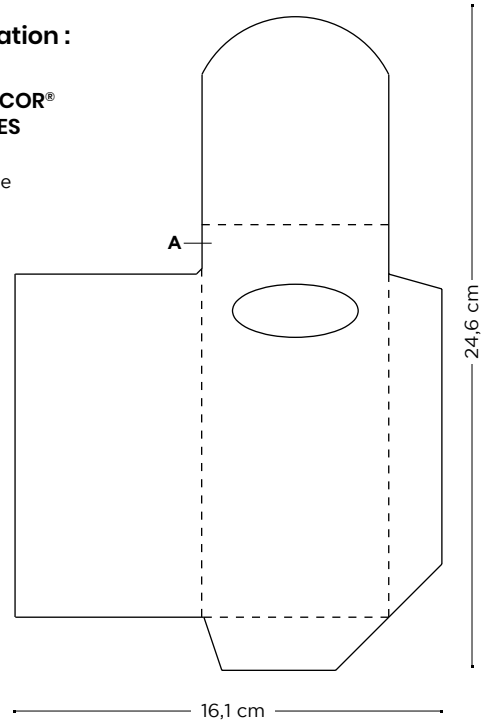

Mode d'écriture :



Techniques d'impression :



(DG)
NUMÉRIQUE

Emballage externe :



84 ± 3,8 Kg

Crayons De Couleur 1202



80%



*Fabriqué avec 50% de matériaux recyclés.

facile à affûter!

Commande minimale 500u.

Personnalisation :

BIC[®] EVOLUTION[®] ECOLUTIONS[®]
LOT DE 6 CRAYONS

1202

A DG: Numérique

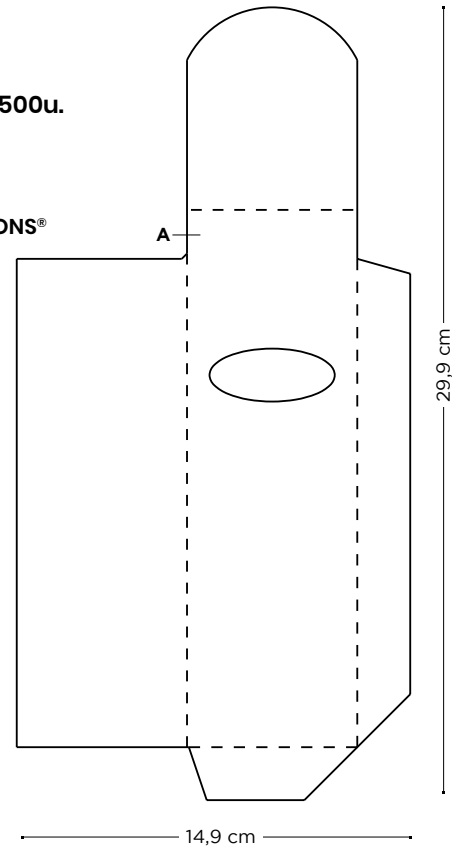

Mode d'écriture :

Techniques d'impression :

Emballage externe :



(DG)
NUMÉRIQUE



60 ± 2,6 Kg



FABRIQUÉ
EN FRANCE



LOT DE 6 CRAYONS



Mine résistante



couleurs vibrantes



Crayons De Couleur 1178

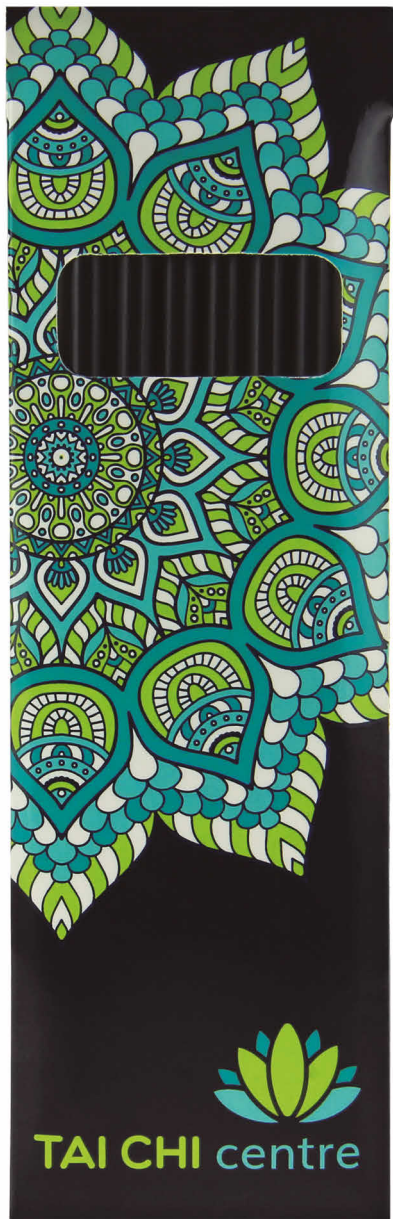

crayons sans bois

80%

Commande minimale 500u.

Personnalisation :

CONTÉ® LOT DE 6 CRAYONS

1178

A DG: Numérique

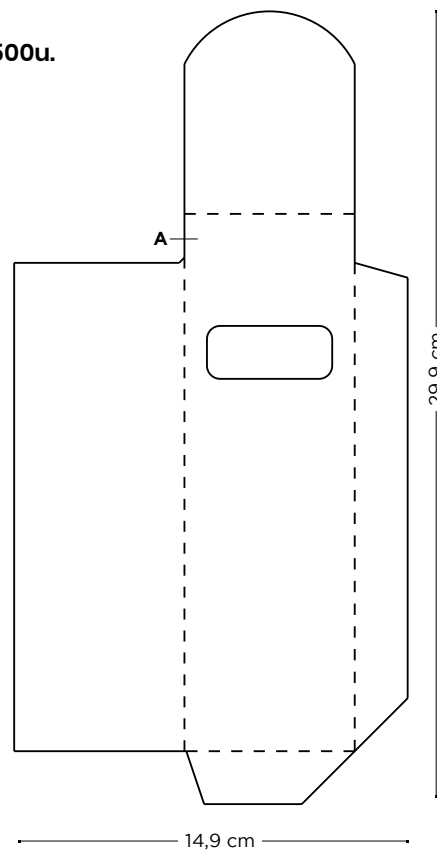

Mode d'écriture :



Techniques d'impression :



(DG)
NUMÉRIQUE

Emballage externe :



60 ± 2,2 Kg



FABRIQUÉ
EN FRANCE

Créez votre propre combinaison

BIC PLASTIDÉCOR LOT DE 6 CRAIES or **BIC** EVOLUTION **ECO**olutions LOT DE 6 CRAYONS



Mode d'écriture :



Emballage :

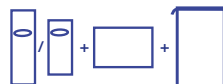

Techniques d'impression :



(SP)
SÉRIGRAPHIE



(OT)
Transfert
numérique

Commande minimale 500u.

Personnalisation :

BIC® PLASTIDECOR®
LOT DE 6 CRAIES
1294



BOX
C DG: Numérique

BAG

Sans impression (sac)
A SP (bag): max 2 col.
B OT (bag): Numérique

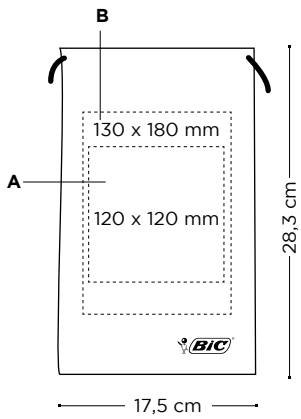

BOOK

C DG: Numérique

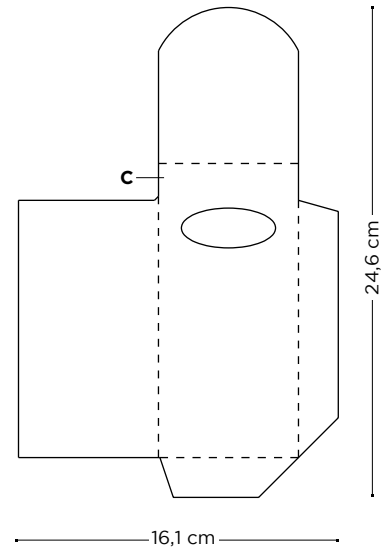
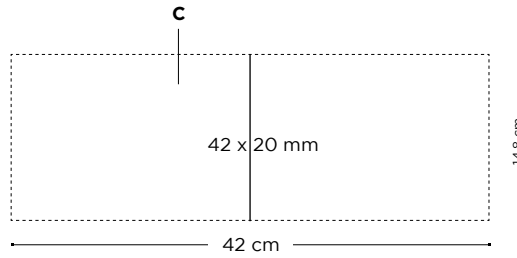

Emballage externe :



100 ± 10,8 Kg

Commande minimale 500u.

Personnalisation :

BIC® EVOLUTION®
ECOLUTIONS®
LOT DE 6 CRAYONS
1293



BAG

Sans impression (sac)
A SP (bag): max 2 col.
B OT (bag): Numérique

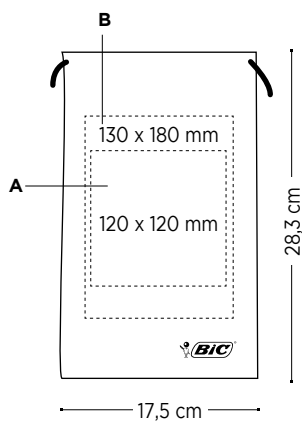

BOOK
C DG: Numérique

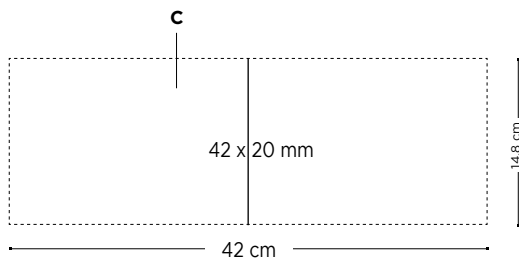

BOX
C DG: Numérique

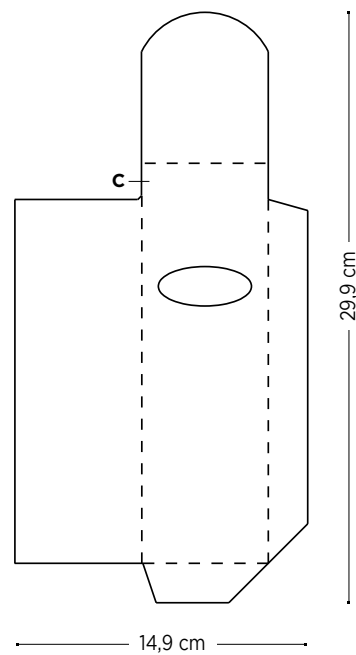

Emballage externe :



100 ± 10,6 Kg

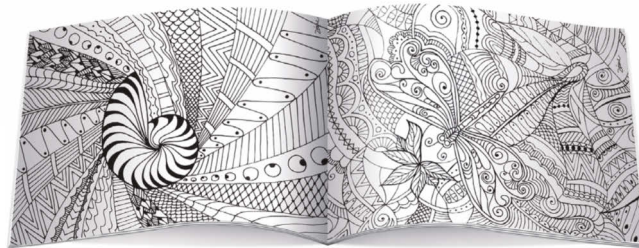

Mode d'écriture :



Techniques d'impression :



(SP)
SÉRIGRAPHIE



(OT)
Transfert
numérique

Emballage externe :



100 ± 10,5 Kg

Commande minimale 500u.

Personnalisation :

CONTÉ® BY BIC® LOT DE COLORIAGE
1292



SAC

Sans impression (sac)

A SP (sac): max 2 col.

B OT (sac): transfert numérique

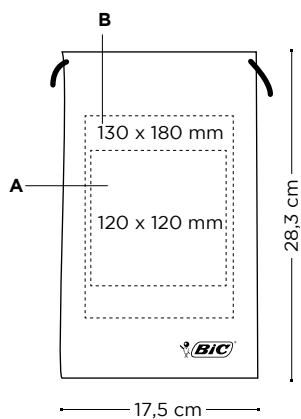

CAHIER

C DG: Numérique

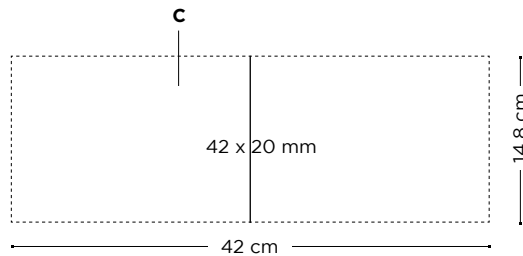

BOÎTE

C DG: Numérique

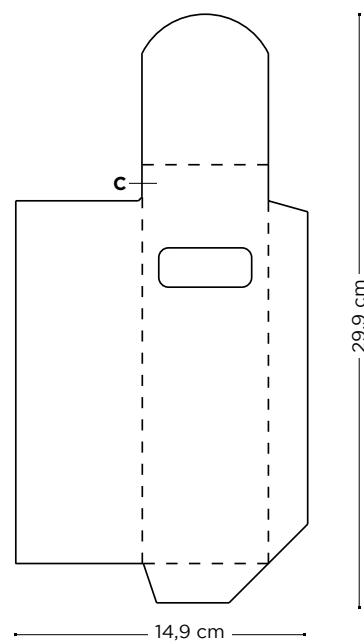

Tipp-Ex MINI POCKET MOUSE *britePix*[™]

Le ruban correcteur Tipp-Ex[®], célèbre dans le monde entier, dans une taille compacte, idéale pour les trousseaux. 6 mètres de ruban 5mm de large indéchirable, pour une application précise par les gauchers comme par les droitiers, le tout sans séchage !





1354



51



51

Commande minimale 250u.

Personnalisation :

MINI POCKET MOUSE

1354

A BP: Quadrichromie

BP Texture: Quadrichromie

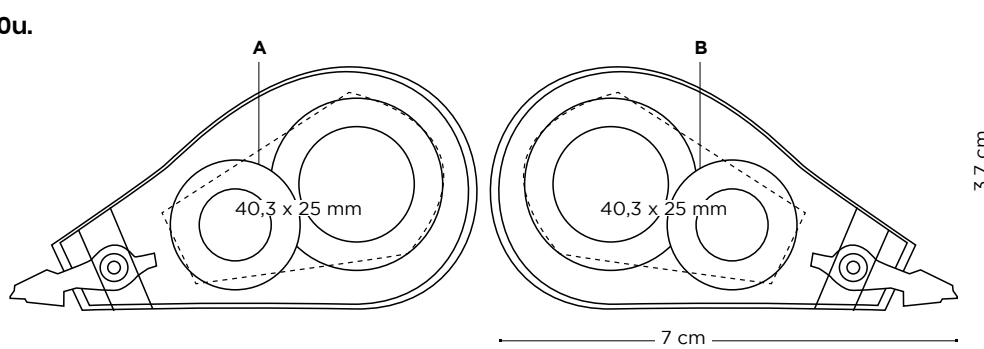

Prix (€)

Mode d'écriture :



T
6 m

* Source: panel GFK - Western Europe 9 - MAT juin 2018 - Ventes en valeur et volume

Techniques d'impression :



(BP)
britePix™



Emballage externe :



288 ± 3,2 Kg

Regardez la video



STYLOS

156 Basic Pen

158 Click Pen

160 Stripped Grip Pen

162 White Striped Grip Pen

STYLOS STYLUS

164 Sleek Stylus Pen

Autres instruments d'écriture

156 — 165

BASIC PEN

Autres instruments d'écriture • STYLOS

12010

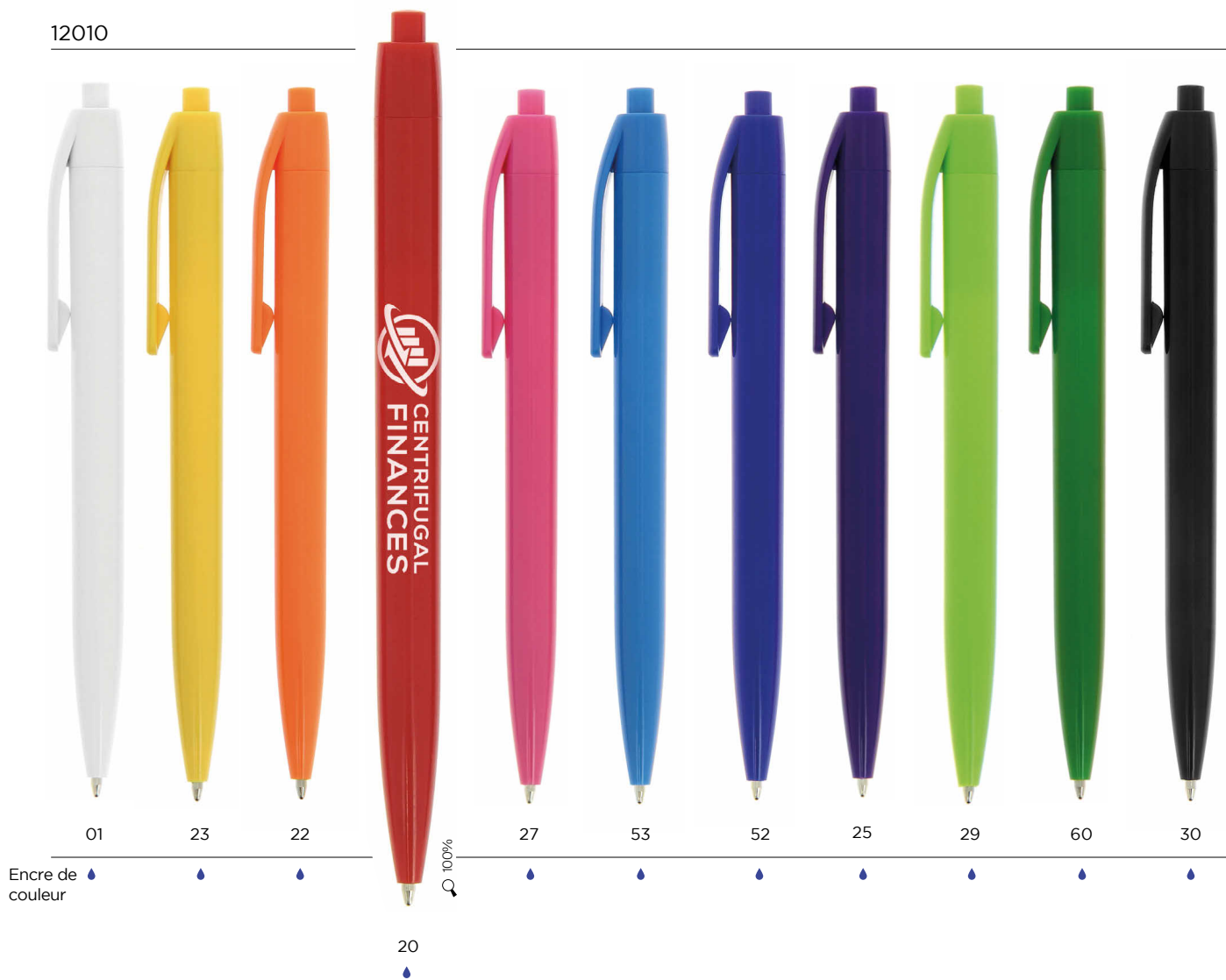

Commande minimale 500u.

Personnalisation :

BASIC PEN
 12010
 A/B SP: max. 1 col.

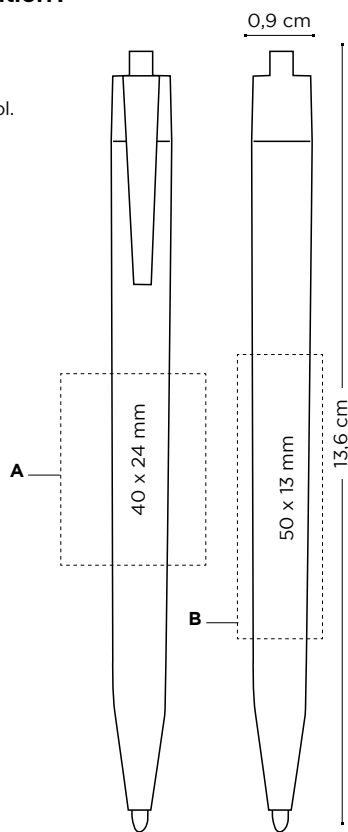

Mode d'écriture :



Techniques d'impression :



Emballage externe :



CLICK PEN

11748



10



23



22

100%



20



27



25



53



50



60



30

Encre de couleur

Commande minimale 500u.

Personnalisation :

CLICK PEN

11748

A/B SP: max. 4 col.

C/D PD: max. 4 col.

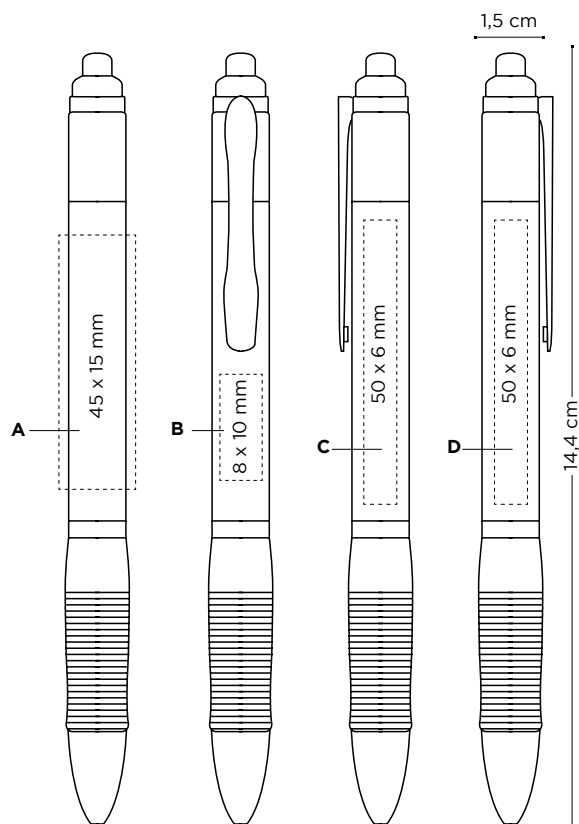

Mode d'écriture :

Bille



M

Techniques d'impression :



(SP)
SÉRIGRAPHIE



(PD)
TAMOGRAPHIE

Emballage externe :



1000 ± 9,5 Kg

STRIPED GRIP PEN

11243



Commande minimale 500u.

Personnalisation :

STRIPED GRIP PEN

11243

A SP: max. 2 col.

B PD: max. 1 col.

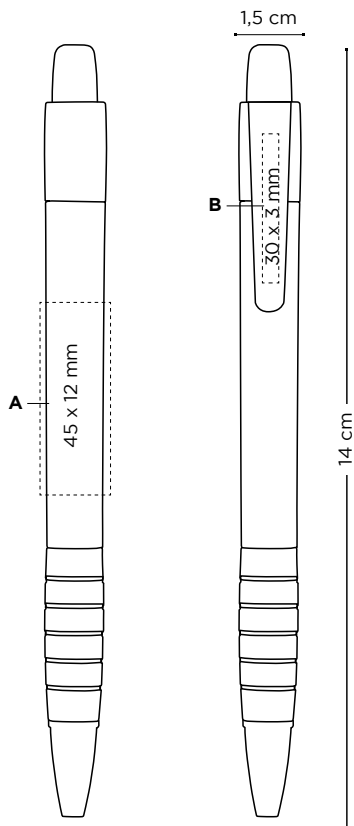

Mode d'écriture :



Techniques d'impression :



Emballage externe :



WHITE STRIPED GRIP PEN

11303



Commande minimale 500u.

Personnalisation :

WHITE STRIPED GRIP PEN

11303

A SP: max. 2 col.

B PD: max. 1 col.

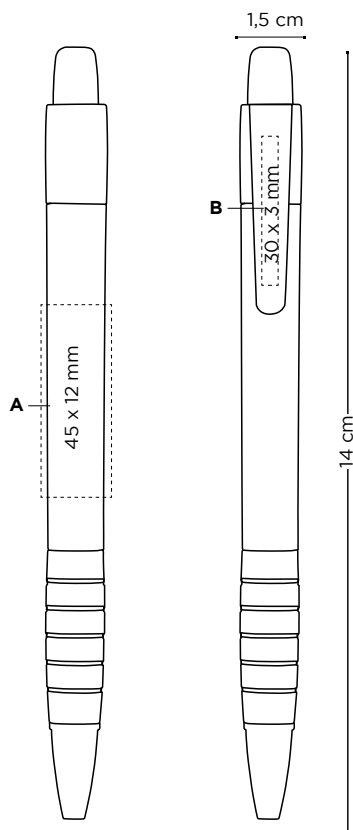

Mode d'écriture :

Bille



M

Techniques d'impression :



(SP)
SÉRIGRAPHIE



(PD)
TAMOGRAPHIE

Emballage externe :



1000 ± 9 Kg

SLEEK STYLUS PEN

SLEEK STYLUS PEN

11666



SLEEK STYLUS MATT PEN

11747



SLEEK STYLUS EXECUTIVE PEN

11976



Commande minimale 100u. (LE)
 Commande minimale 500u. (SP)

Personnalisation :

SLEEK STYLUS PEN

11666

SLEEK STYLUS MATT PEN

11747

**SLEEK STYLUS EXECUTIVE
 PEN**

11976

A SP: max. 1 col.

B SP: max. 2 col.

C/D/E/F LE

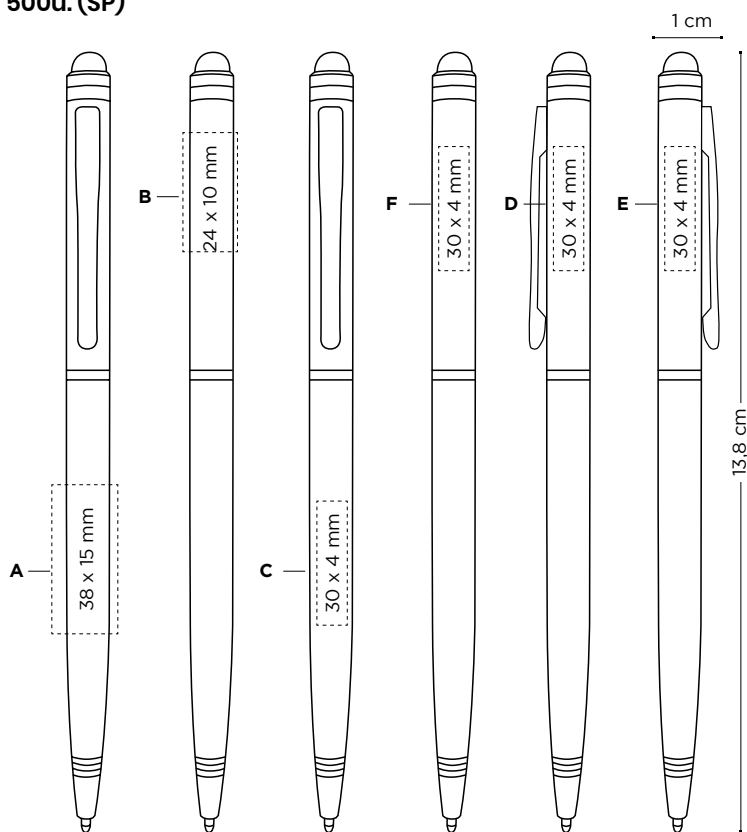

Mode d'écriture :

Bille



M

Techniques d'impression :



(SP)
 SÉRIGRAPHIE



(LE)
 LASER

Emballage externe :



900 ± 12,4 Kg



800 ± 13 Kg

Gravure laser non disponible en couleur jaune / argent

BLOC-NOTES ADHÉSIFS

- 170** BIC® 50 mm x 75 mm
Adhesive Notepads
- 172** BIC® 68 mm x 75 mm
Adhesive Notepads
- 174** BIC® 75 mm x 75 mm
Adhesive Notepads
- 176** BIC® Small Adhesive Die
Cut Notepads
- 178** BIC® 101 mm x 75 mm
Adhesive Notepads
& BIC® 101 mm x 75 mm
Alternating Sheet Imprint
- 180** BIC® Medium Adhesive
Die Cut Notepads
- 182** BIC® 101 mm x 101 mm
Adhesive Notepads
- 184** BIC® 101 mm x 130 mm
Adhesive Notepads

SCRATCH PADS

- 186** BIC® 75 x 127 mm
Non-Adhesive Scratch Pad
- 187** BIC® 96 x 152 mm
Non-Adhesive Scratch Pad

BOOKLETS

- 190** BIG Flag Booklet
- 192** BIC® 75 x 75 Booklet
- 194** BIC® 101 x 75 Booklet
- 196** BIC® 75 x 75 Adhesive
Notepad With Flag Booklet
- 198** BIC® Clic Stic Organiser
& BIC® Clic Stic Mini
Digital Organiser
- 202** BIC® 150 x 150 mm Booklet
Organiser
- 204** BIC® 150 x 150 mm Booklet
With Pen Loop



**Notes
adhesives**

168 — 205



 **NOTES ADHESIVES**

Les Sticky Notes BIC®, l'outil indispensable dans votre bureau. Choisissez entre plusieurs formes et dimensions disponibles, adhésifs ou non.

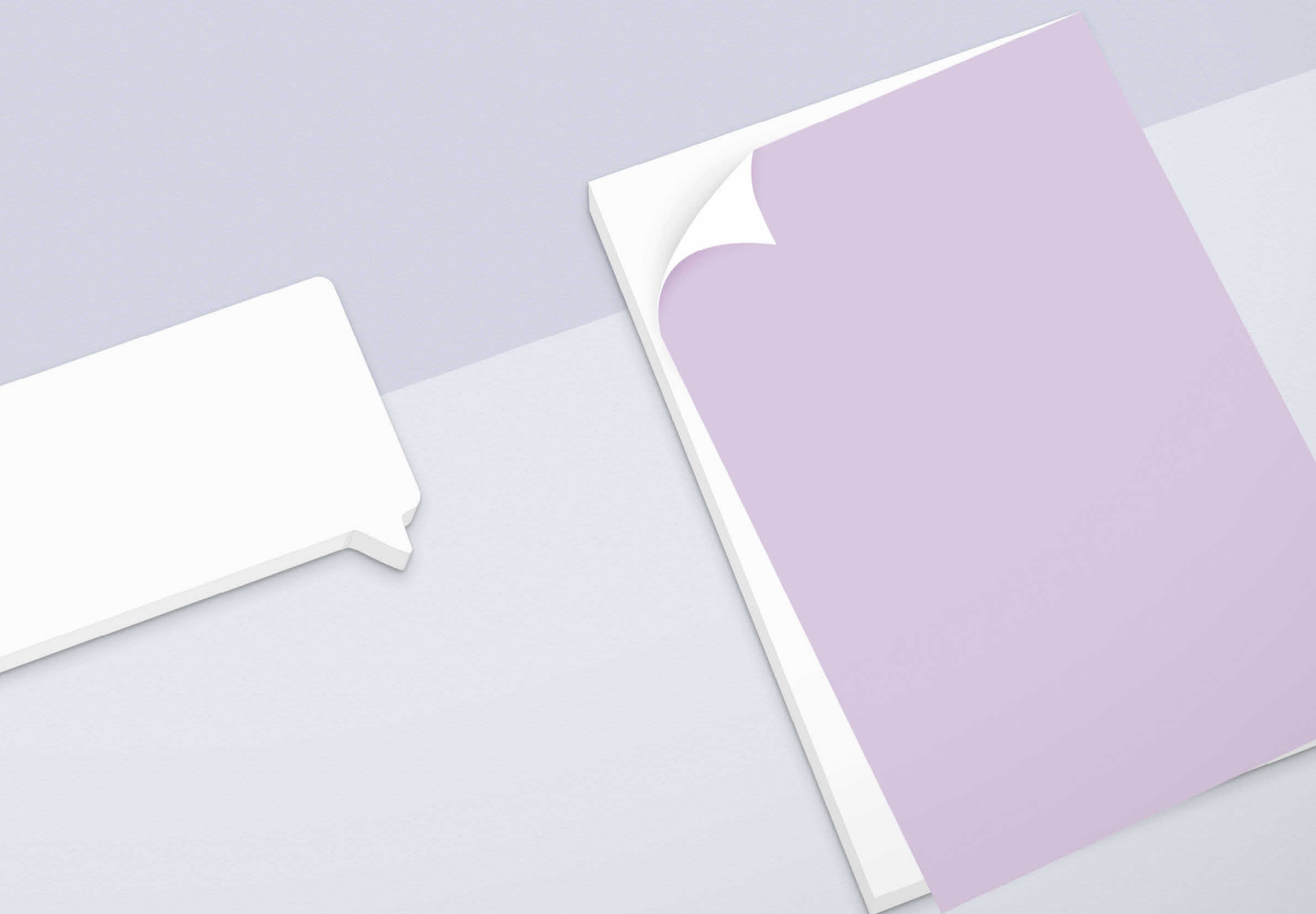



50 MM X 75 MM ADHESIVE NOTEPADS

VERSIONS **ecolutions**® DISPONIBLES

FABRIQUÉ À PARTIR DE 100% DE PAPIER CERTIFIÉ FSC ET **100% RECYCLABLE**



150%



100%

Dimension idéale pour les notes en entreprise !

Marquage d'une couleur spécifique :

≥ 500 unités

Type de papier :

- Standard 80g
- Recyclé 80g

Emballage spécial:

Emballage sous film plastique

N° de feuilles	Unités par pack
25	10
50	5
100	1

Techniques d'impression :



(DG) QUADRICHROMIE









FABRIQUÉ EN ESPAGNE

VERSION ECOLUTIONS: FABRIQUÉ À PARTIR DE 100% DE FIBRE RECYCLÉE* ET **100% RECYCLABLE**
 VERSION NON ECOLUTIONS: FABRIQUÉ À PARTIR DE 100% DE PAPIER CERTIFIÉ FSC ET **100% RECYCLABLE**

Personnalisation : Commande minimale 500u.

**BIC® 50 MM X 75 MM
 ADHESIVE NOTEPADS
 A DG: quadrichromie**

-  25 **3522**
 **3520**
-  50 **3552**
 **3550**
-  100 **3582**
 **3580**

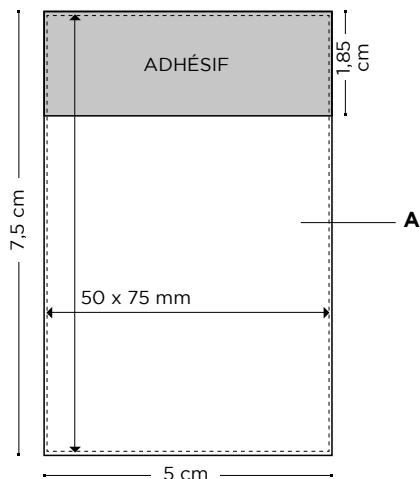

Emballage externe :

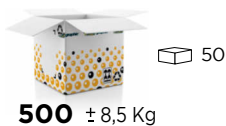
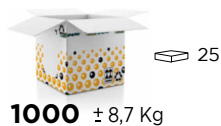

*Pourcentage calculé hors dernière page



68 MM X 75 MM ADHESIVE NOTEPADS

VERSIONS **ecolutions**® DISPONIBLES

FABRIQUÉ À PARTIR DE 100% DE PAPIER CERTIFIÉ FSC ET **100% RECYCLABLE**



130%



Bloc-notes sticky Notes idéaux pour toujours emporter vos messages avec vous !

Marquage d'une couleur spécifique :

≥ 500 unités

Type de papier :

- Standard 80g
- Recyclé 80g

Emballage spécial: **Emballage sous film plastique**

N° de feuilles	Unités par pack
25	10
50	5
100	1

Techniques d'impression :



(DG)
QUADRICROMIE



FABRIQUÉ EN ESPAGNE







Emballage optionnel:
Sachet plastique 1, 2, 3 unités

VERSION ECOLUTIONS: FABRIQUÉ À PARTIR DE 100% DE FIBRE RECYCLÉE* ET **100% RECYCLABLE**
 VERSION NON ECOLUTIONS: FABRIQUÉ À PARTIR DE 100% DE PAPIER CERTIFIÉ FSC ET **100% RECYCLABLE**

Personnalisation : Commande minimale 500u.

**BIC® 68 MM X 75 MM
 ADHESIVE NOTEPADS**

A DG: quadrichromie

-  25 **3502**
 **3500**
-  50 **3532**
 **3530**
-  100 **3562**
 **3560**

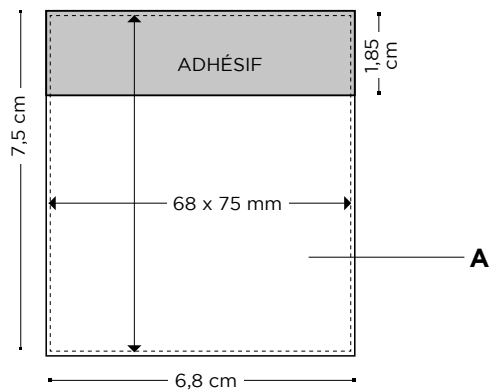

Emballage externe :

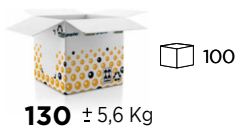

*Pourcentage calculé hors dernière page

BIC 75 MM X 75 MM ADHESIVE NOTEPADS

VERSIONS **ecolutions**® DISPONIBLES

FABRIQUÉ À PARTIR DE 100% DE PAPIER
CERTIFIÉ FSC ET **100% RECYCLABLE**



130%



Grande zone d'impression avec une taille mini !

Marquage d'une
couleur spécifique :

≥ 500 unités

Type de papier :

- Standard 80g
- Recyclé 80g

Emballage spécial:
Emballage sous film plastique

N° de feuilles	Unités par pack
25	10
50	5
100	1

Techniques d'impression :



(DG)
QUADRICHROMIE





FABRIQUÉ EN
ESPAGNE

VERSION ECOLUTIONS: FABRIQUÉ À PARTIR DE 100% DE FIBRE RECYCLÉE* ET **100% RECYCLABLE**
VERSION NON ECOLUTIONS: FABRIQUÉ À PARTIR DE 100% DE PAPIER CERTIFIÉ FSC ET **100% RECYCLABLE**

Personnalisation : **Commande minimale 500u.**

**BIC® 75 MM X 75 MM
ADHESIVE NOTEPADS**

A DG: quadrichromie

-  25 **ecolutions® 3505**
-  50 **ecolutions® 3535**
-  100 **ecolutions® 3565**

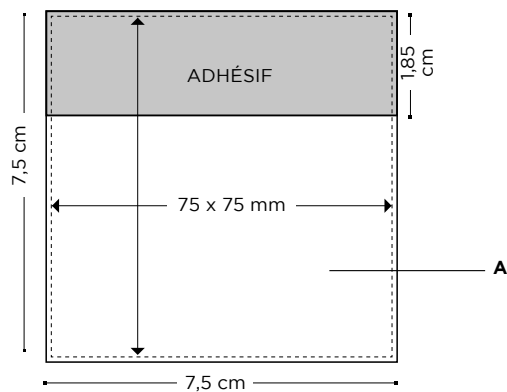

Emballage externe :

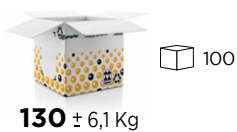
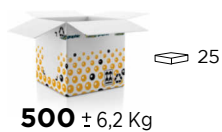

*Pourcentage calculé hors dernière page



Choisissez parmi les 7 formes en stock !
Formes spéciales sur demande

Marquage d'une couleur spécifique :

≥ 500 unités

Type de papier :

Standard 80g

Emballage spécial:
Emballage sous film plastique

N° de feuilles	Unités par pack
25	10
50	5
100	1

Techniques d'impression :



(DG)
QUADRICHROMIE



FABRIQUÉ EN ESPAGNE

Emballage optionnel:
Sachet plastique 1, 2, 3 unités

FABRIQUÉ À PARTIR DE 100% DE PAPIER
CERTIFIÉ FSC ET **100% RECYCLABLE**

Personnalisation : Commande minimale 500u.

**BIC® SMALL ADHESIVE
DIE CUT NOTEPADS**

A DG: quadrichromie

 25 3603

 50 3607

 100 3611

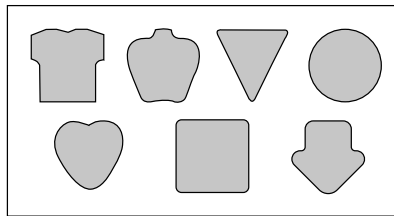
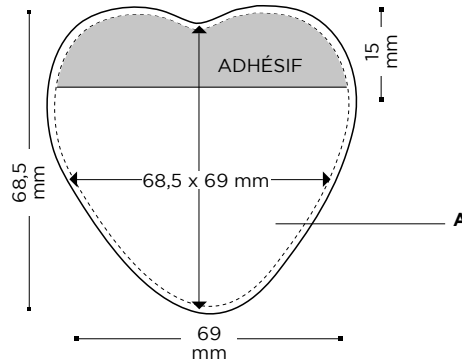

Emballage externe :



500 ± 6,2 Kg



250 ± 6 Kg



130 ± 6,2 Kg



**101 MM X 75 MM ADHESIVE NOTEPADS
& BIC® 101 MM X 75 MM ALTERNATING SHEET IMPRINT**

VERSIONS **ecolutions®** DISPONIBLES

FABRIQUÉ À PARTIR DE 100% DE PAPIER
CERTIFIÉ FSC ET **100% RECYCLABLE**



Indispensable dans
n'importe quel bureau !
Le sticky notes de la
taille la plus populaire !



100%



Alternez 2 messages pour un double impact !

Marquage d'une
couleur spécifique :

≥ 500 unités

Type de papier :

- Standard 80g
- Recyclé 80g

Emballage spécial:
Emballage sous film plastique

N° de feuilles	Unités par pack
25	10
50	5
100	1

Techniques d'impression :



(DG)
QUADRICHROMIE



FABRIQUÉ EN
ESPAGNE



Emballage optionnel:
Sachet plastique 1, 2, 3 unités

VERSION ECOLUTIONS: FABRIQUÉ À PARTIR DE 100% DE FIBRE RECYCLÉE* ET **100% RECYCLABLE**
 VERSION NON ECOLUTIONS: FABRIQUÉ À PARTIR DE 100% DE PAPIER CERTIFIÉ FSC ET **100% RECYCLABLE**

Personnalisation :

**BIC® 101 MM X 75 MM ADHESIVE NOTEPADS
 & ALTERNATING SHEET IMPRINT**

A DG: quadrichromie

-  25 **@@olutions® 3510**
 Feuilles alternées 3514
-  50 **@@olutions® 3540**
 Feuilles alternées 3544
-  100 **@@olutions® 3570**

Commande minimale 500u.

Commande minimale 250u.

Commande minimale 500u.

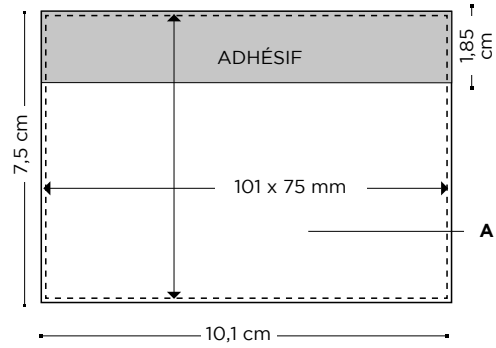

Emballage externe :

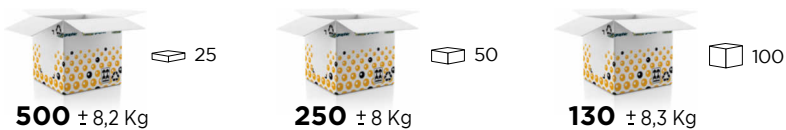

*Pourcentage calculé hors dernière page



MEDIUM ADHESIVE DIE CUT NOTEPADS

VERSIONS **ecolutions**® DISPONIBLES

FABRIQUÉ À PARTIR DE 100% DE PAPIER
CERTIFIÉ FSC ET **100% RECYCLABLE**



125%

Choisissez parmi les 28 formes en stock !
Formes spéciales sur demande

Marquage d'une couleur spécifique :

≥ 500 unités

Type de papier :

- Standard 80g
- Recyclé 80g

Emballage spécial:
Emballage sous film plastique

N° de feuilles	Unités par pack
25	10
50	5
100	1

Techniques d'impression :



(DG)
QUADRICHROMIE



FABRIQUÉ EN ESPAGNE









Emballage optionnel:
Sachet plastique 1, 2, 3 unités

VERSION ECOLUTIONS: FABRIQUÉ À PARTIR DE 100% DE FIBRE RECYCLÉE* ET **100% RECYCLABLE**
 VERSION NON ECOLUTIONS: FABRIQUÉ À PARTIR DE 100% DE PAPIER CERTIFIÉ FSC ET **100% RECYCLABLE**

Personnalisation : Commande minimale 500u.

**BIC® MEDIUM ADHESIVE
 DIE CUT NOTEPADS**

A DG: quadrichromie

-  25  3604
 3602
-  50  3608
 3606
-  100  3612
 3610

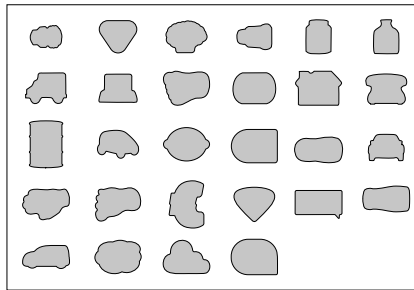
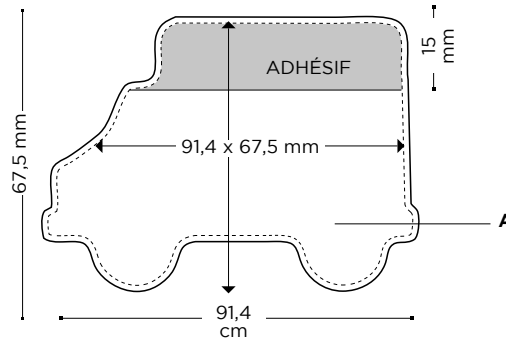

Emballage externe :

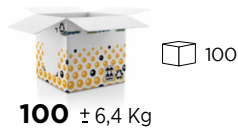
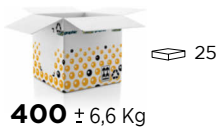

*Pourcentage calculé hors dernière page



101 MM X 101 MM ADHESIVE NOTEPADS

VERSIONS **ecolutions**® DISPONIBLES

FABRIQUÉ À PARTIR DE 100% DE PAPIER CERTIFIÉ FSC ET **100% RECYCLABLE**



BIC Notes adhesives • BLOC-NOTES ADHÉSIFS

Profitez de sa large zone d'impression !

Marquage d'une couleur spécifique :

≥ 500 unités

Type de papier :

- Standard 80g
- Recyclé 80g

Emballage spécial: **Emballage sous film plastique**

N° de feuilles	Unités par pack
25	10
50	5
100	1

Techniques d'impression :



(DG) QUADRICROMIE





FABRIQUÉ EN ESPAGNE

VERSION ECOLUTIONS: FABRIQUÉ À PARTIR DE 100% DE FIBRE RECYCLÉE* ET **100% RECYCLABLE**
VERSION NON ECOLUTIONS: FABRIQUÉ À PARTIR DE 100% DE PAPIER CERTIFIÉ FSC ET **100% RECYCLABLE**

Personnalisation : **Commande minimale 500u.**

**BIC® 101 MM X 101 MM
ADHESIVE NOTEPADS**

A DG: quadrichromie

-  25 **ecolutions® 3516**
-  50 **ecolutions® 3546**
-  100 **ecolutions® 3576**

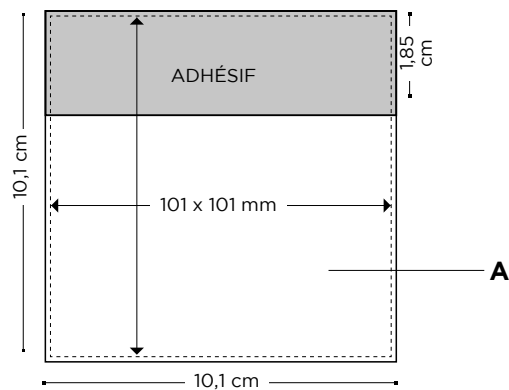

Emballage externe :

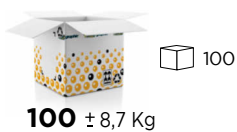
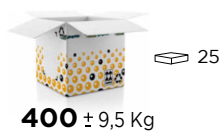

*Pourcentage calculé hors dernière page

BIC 101 MM X 130 MM ADHESIVE NOTEPADS

VERSIONS **ecolutions**® DISPONIBLES

FABRIQUÉ À PARTIR DE 100% DE PAPIER CERTIFIÉ FSC ET **100% RECYCLABLE**

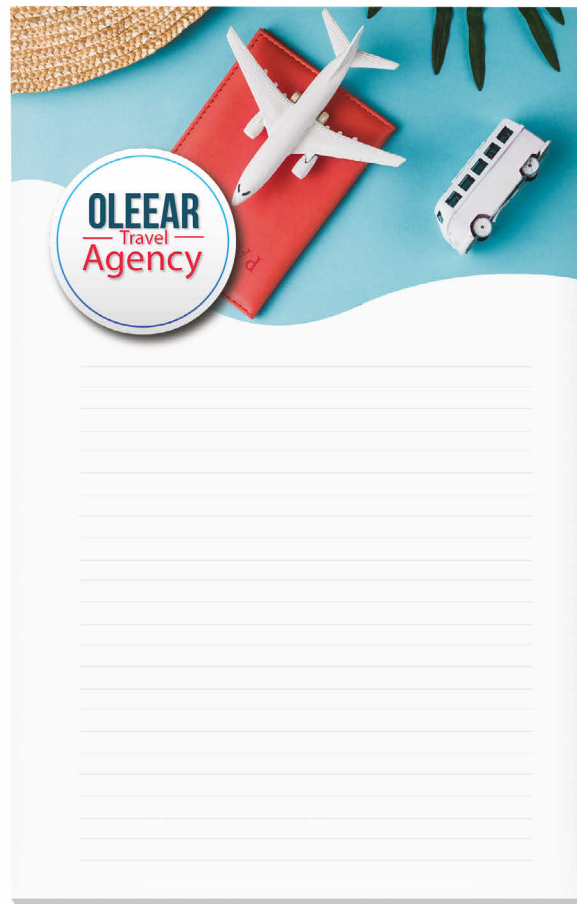
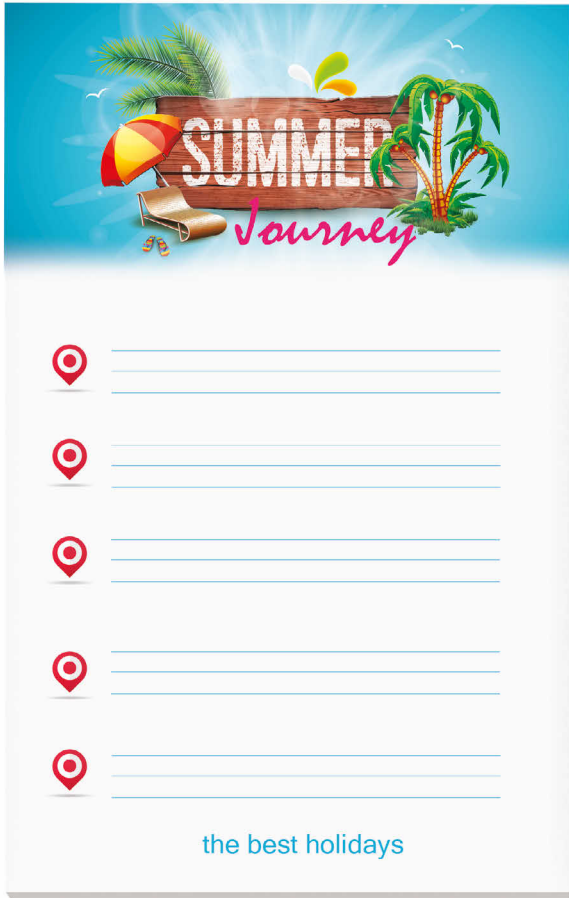

Grande surface d'impression pour de grands messages !
Pour que rien ne vous échappe !

BIC Notes adhesives • BLOC-NOTES ADHÉSIFS

130%

Marquage d'une couleur spécifique :

≥ 500 unités

Type de papier :

- Standard 80g
- Recyclé 80g

Emballage spécial:
Emballage sous film plastique

N° de feuilles	Unités par pack
25	10
50	5
100	1

Techniques d'impression :



(DG)
QUADRICROMIE









FABRIQUÉ EN ESPAGNE

VERSION ECOLUTIONS: FABRIQUÉ À PARTIR DE 100% DE FIBRE RECYCLÉE* ET **100% RECYCLABLE**
 VERSION NON ECOLUTIONS: FABRIQUÉ À PARTIR DE 100% DE PAPIER CERTIFIÉ FSC ET **100% RECYCLABLE**

Personnalisation : Commande minimale 500u.

**BIC® 101 MM X 130 MM
 ADHESIVE NOTEPADS**

A DG: quadrichromie

-  25  **3517**
-  50  **3547**
-  100  **3577**

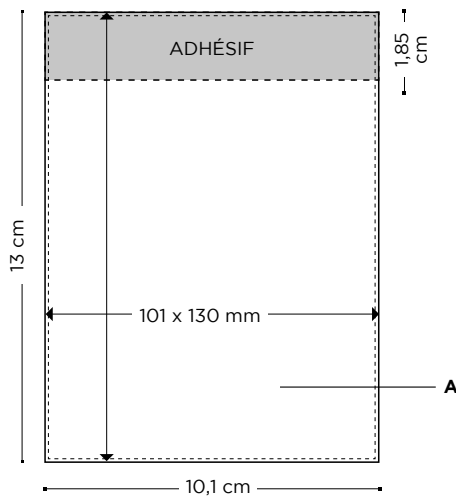

Emballage externe :

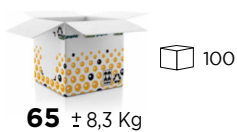
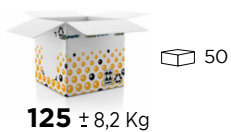

*Pourcentage calculé hors dernière page



75 X 127 MM NON-ADHESIVE SCRATCH PAD

Blocs papier Non Adhesifs, indispensable pour listes et notes

FABRIQUÉ À PARTIR DE 100% DE PAPIER CERTIFIÉ FSC ET 100% RECYCLABLE



3760 / 3761



Commande minimale 500u.

Personnalisation :

BIC® 75 X 127 NON-ADHESIVE SCRATCH PAD
A DG: quadrichromie

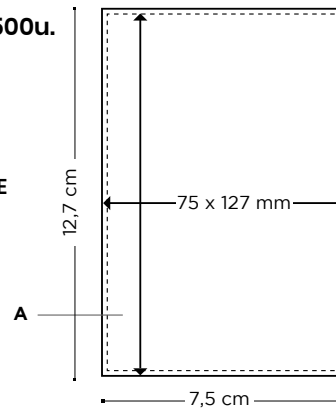

Type de papier :

Standard 60g

Techniques d'impression :



(DG)
QUADRICHROMIE

Emballage externe :



20

400 ± 5,4 Kg



40

200 ± 5,2 Kg

Emballage optionnel:
Sachet plastique 1, 2, 3 unités



FABRIQUÉ EN ESPAGNE

FABRIQUÉ À PARTIR DE 100% DE PAPIER
CERTIFIÉ FSC ET **100% RECYCLABLE**



3762 / 3763



Commande minimale 500u.

Personnalisation :

**BIC® 96 X 152 NON-ADHESIVE
SCRATCH PAD**

A DG: quadrichromie

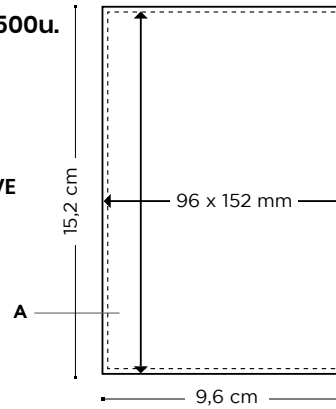

Type de papier :

Standard 60g

Techniques d'impression :



(DG)
QUADRICHROMIE

Emballage externe :



350 ± 8,6 Kg



200 ± 8 Kg

Emballage optionnel:
Sachet plastique 1, 2, 3 unités



FABRIQUÉ EN
ESPAGNE



Un objet multifonctionnel idéal pour la prise de notes !
Double impact de votre message grâce à la couverture
personnalisée et au bloc-notes Sticky Notes.







120%

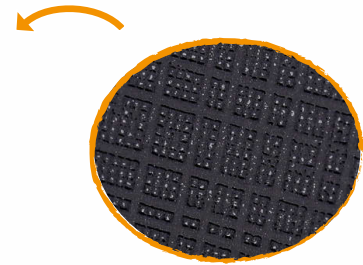

Choisissez une finition de couverture pour votre livret: brillant, motif laminé ou feuilleté mat au toucher doux.



25 marque-pages adhésifs de chaque couleur!

Emballage spécial:

Emballage sous film plastique:
10 Booklets

Techniques d'impression :



(DG)
QUADRICROMIE





FABRIQUÉ EN ESPAGNE

Personnalisation :

BIC® FLAG BOOKLET
A/B DG: quadrichromie

Commande minimale 250u.

 25 3730

 25 Marque-pages par couleur

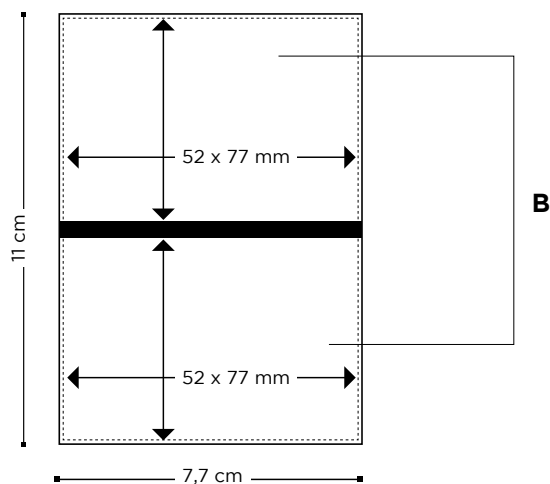
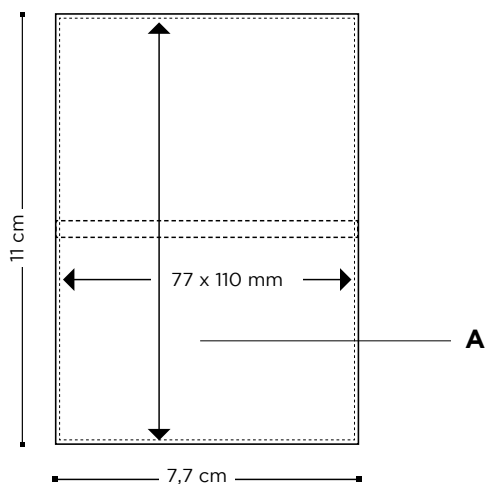

Emballage externe :



 25

150 ± 1,56 Kg

Emballage optionnel:
Sachet plastique 1, 2, 3 unités

FABRIQUÉ À PARTIR DE 100% DE PAPIER
CERTIFIÉ FSC ET **100% RECYCLABLE**



Type de papier :

Standard 80g

Emballage spécial:

Emballage sous film plastique:
10 Booklets

Emballage optionnel:
Sachet plastique 1, 2 unités

Techniques d'impression :



(DG)
QUADRICHROMIE





FABRIQUÉ EN
ESPAGNE

Personnalisation :

BIC® 75 X 75 BOOKLET
A/B/C/D DG: quadrichromie

Commande minimale avec bloc non imprimé : 250u.
Commande minimale avec bloc imprimé : 500u.

-  25 3731
-  50 3737

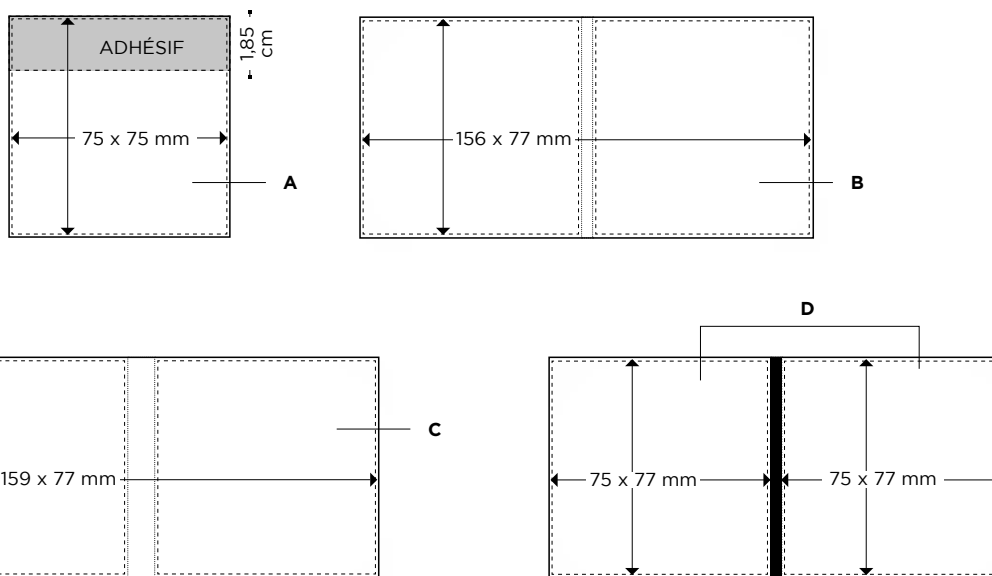

External Packaging:

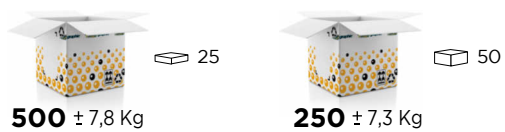

FABRIQUÉ À PARTIR DE 100% DE PAPIER
CERTIFIÉ FSC ET **100% RECYCLABLE**



Double impact de votre message grâce
à la couverture personnalisée et au bloc-notes
sticky notes dans sa taille la plus populaire

Type de papier :

Standard 80g

Emballage spécial:

Emballage sous film plastique:
10 Booklets

Emballage optionnel:
Sachet plastique 1, 2, 3 unités

Techniques d'impression :



(DG)
QUADRICHROMIE



FABRIQUÉ EN
ESPAGNE

Personnalisation :

BIC® 101 X 75 BOOKLET

E/F/G/H DG: quadrichromie

- 📦 25 3738 **Commande minimale avec bloc non imprimé : 250u / Commande minimale avec bloc imprimé : 500u.**
- 📦 50 3739 **Commande minimale avec bloc imprimé : 250u.**

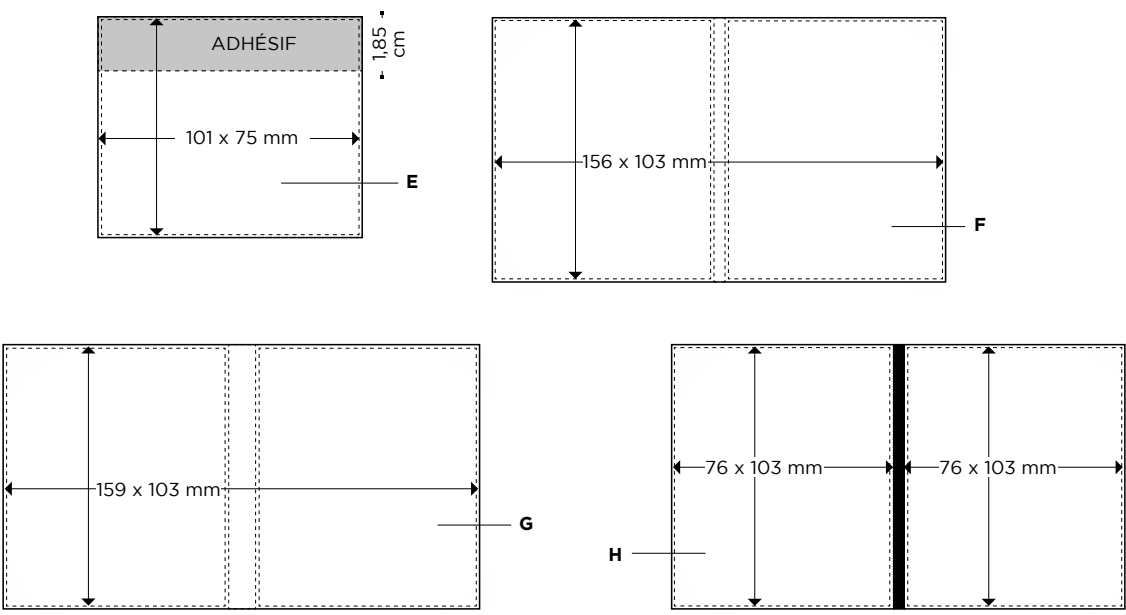

Emballage externe :

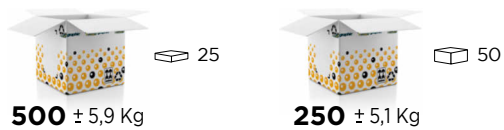



75 X 75 ADHESIVE NOTEPAD WITH FLAG BOOKLET

FABRIQUÉ À PARTIR DE 100% DE PAPIER
CERTIFIÉ FSC ET **100% RECYCLABLE**



70%

*Le bloc multifonction
pour la prise de notes*

Type de papier :

Standard 80g

Emballage spécial:

Emballage sous film plastique:
10 Booklets

Emballage optionnel:
Sachet plastique 1, 2, 3 unités

Techniques d'impression :



(DG)
QUADRICHROMIE



FABRIQUÉ EN
ESPAGNE

Personnalisation :

**BIC® ADHESIVE NOTEPAD
WITH FLAG BOOKLET**
A/B/C DG: quadrichromie

Commande minimale avec bloc non imprimé : 250u.

Commande minimale avec bloc imprimé : 500u.

 25 3732

 25 Marque-pages par couleur

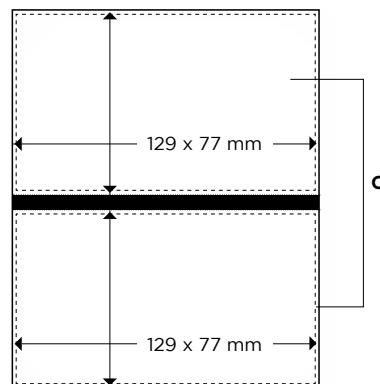
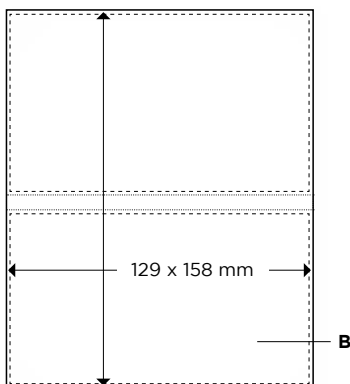
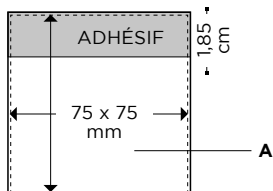

Emballage externe :



 25

200 ± 5,2 Kg



CLIC STIC MINI ORGANISER & BIC® CLIC STIC MINI DIGITAL ORGANISER

FABRIQUÉ À PARTIR DE 100% DE PAPIER
CERTIFIÉ FSC ET **100% RECYCLABLE**



BIC® CLIC STIC MINI ORGANISER

3733



Utilisez ce set de rangement
tout-en-un pour vos réunions
et vos notes quotidiennes



Cet article exceptionnel pour une communication très impactante comprend un stylo BIC® Clic Stic Mini Digital

BIC® CLIC STIC MINI DIGITAL ORGANISER
3735



Image photographique sur tous les côtés !



Combinaison de couleurs standards



Bouton

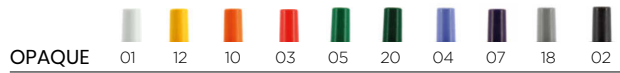
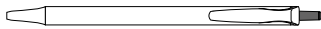

Clip

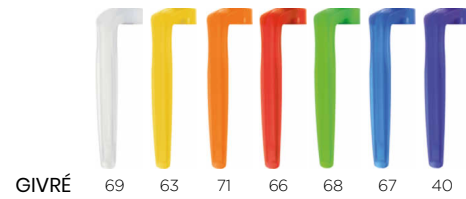
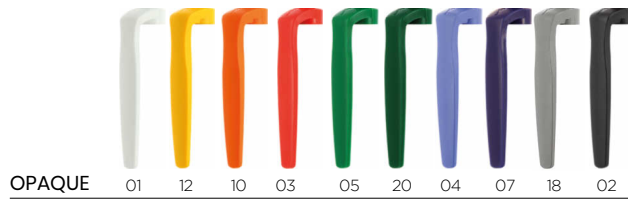
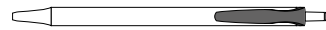

Section

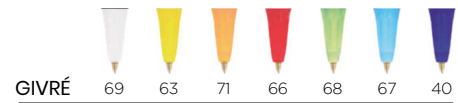

Corps



Type de papier :



Standard 80g

Emballage spécial:

Emballage sous film plastique:
10 Booklets

Emballage optionnel:
Sachet plastique 1, 2 unités

Techniques d'impression :



(DG)
QUADRICHROMIE



FABRIQUÉ EN
ESPAGNE

Personnalisation :

BIC® CLIC STIC MINI ORGANISER

3733

BIC® CLIC STIC MINI DIGITAL ORGANISER

3735

A/B/C DG: quadrichromie.

D/E SP: max 1 col.

F DG: quadrichromie (zone texte)
(disponible en corps blanc)

G DG: quadrichromie (zone image)
(disponible en corps blanc)

 20 Bloc-notes adhésifs

 40 Scratch pad

 25 Marque-pages par couleur

**Commande minimale avec
bloc non imprimé : 250u.**

**Commande minimale avec
bloc imprimé : 500u.**

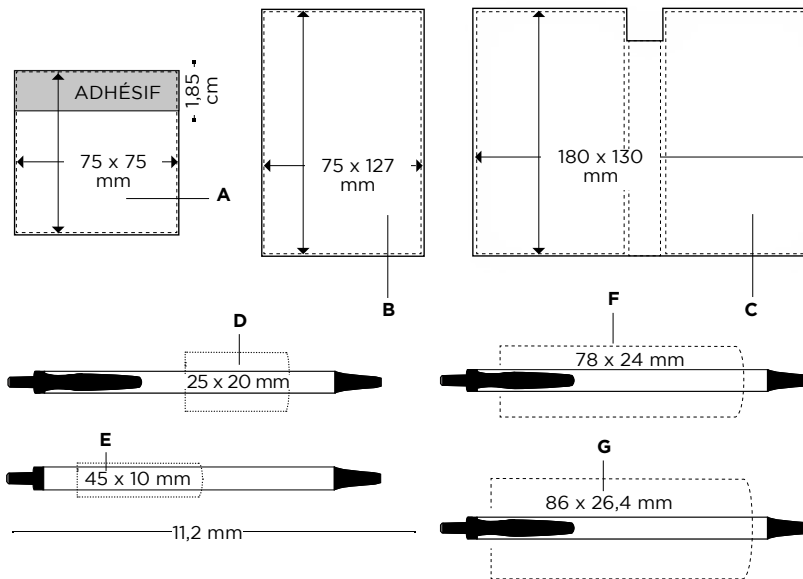

Emballage externe :



125 ± 7 Kg

FABRIQUÉ À PARTIR DE 100% DE PAPIER
CERTIFIÉ FSC ET **100% RECYCLABLE**

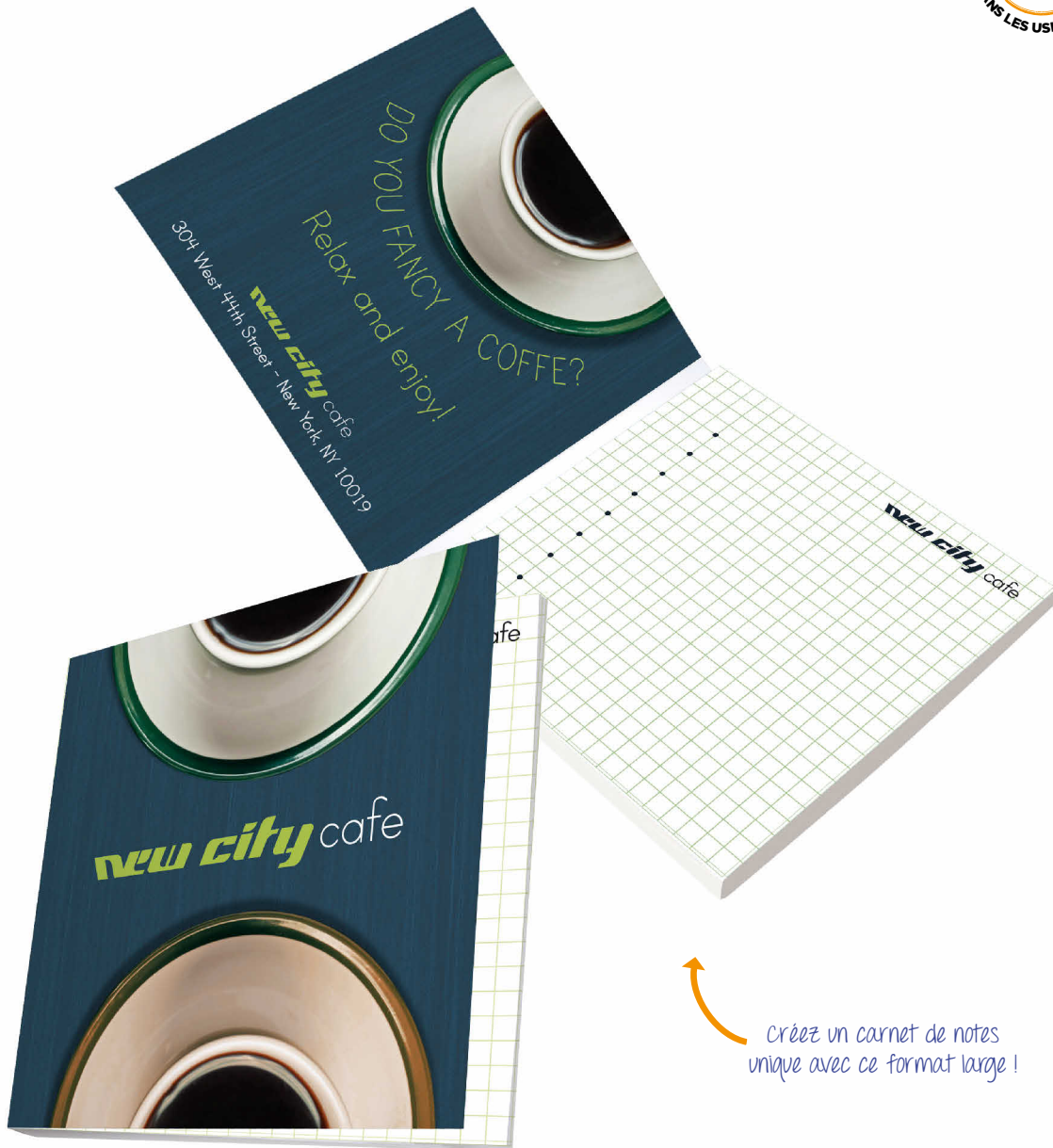

Créez un carnet de notes
unique avec ce format large !

Type de papier :

Standard 80g

Emballage spécial:

Emballage sous film plastique:
10 Booklets

Techniques d'impression :



(DG)
QUADRICHROMIE



FABRIQUÉ EN
ESPAGNE

Personnalisation :

BIC® 150 X 150
BOOKLET ORGANISER
A/B/C DG: quadrichromie

Commande minimale 500u.

 100 3745

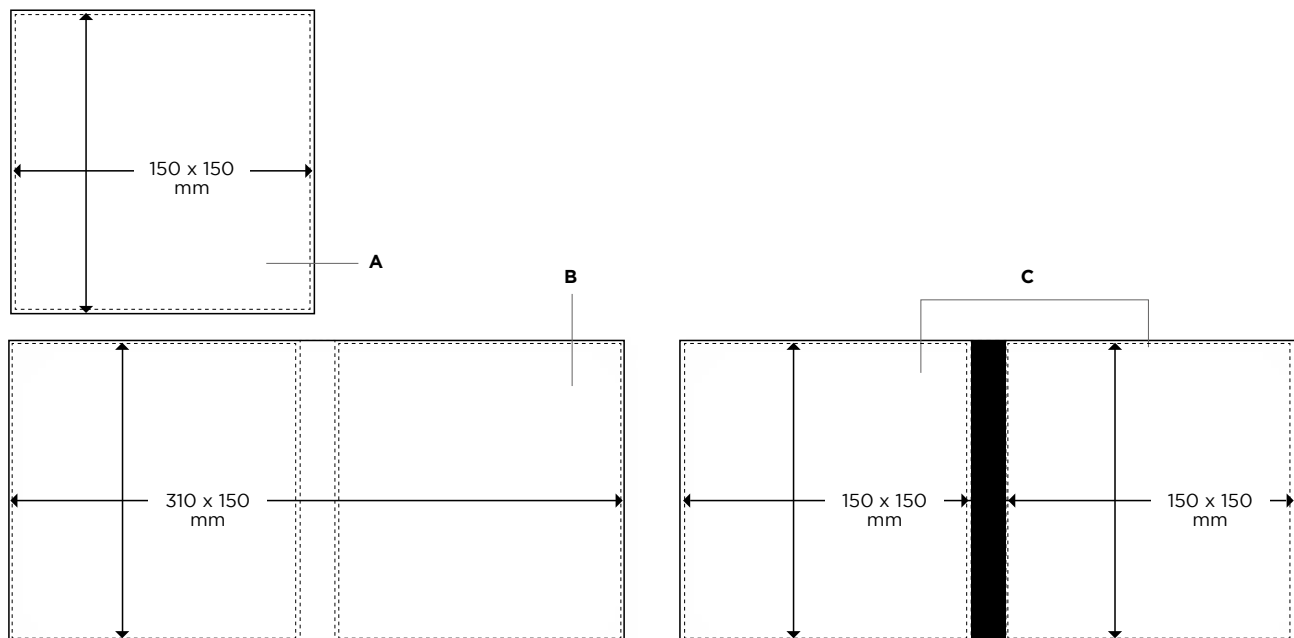

Emballage externe :



40 ± 6,4 Kg

FABRIQUÉ À PARTIR DE 100% DE PAPIER
CERTIFIÉ FSC ET **100% RECYCLABLE**

3746



Avec porte-stylo

Suggestion de présentation
avec le BIC® wide Body™ Digital.
Combinez cet article avec n'importe
quel produit d'écriture

BIC® Notes adhesives • BOOKLETS

Type de papier :

Standard 80g

Emballage spécial:

Emballage sous film plastique:
10 Booklets

Emballage optionnel:
Sachet plastique 1, 2, 3 unités

Techniques d'impression :



(DG)
QUADRICHROMIE

Emballage externe :



40 ± 6,7 Kg



FABRIQUÉ EN
ESPAGNE

Personnalisation :

BIC® 150 X 150 BOOKLET WITH PEN LOOP

A/B/C DG: quadrichromie

D/F SP: max. 2 col.

E/I SP: max. 1 col.

G DG: quadrichromie (zone image)

H DG: quadrichromie (zone texte)

100 3746

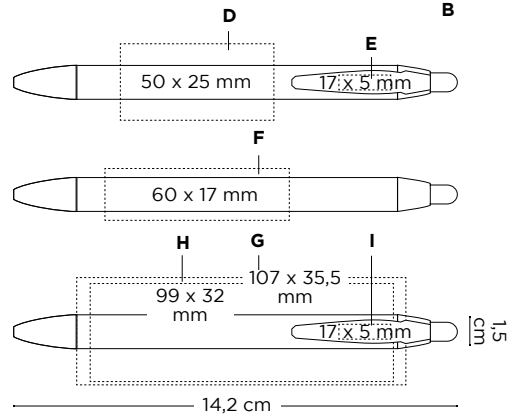
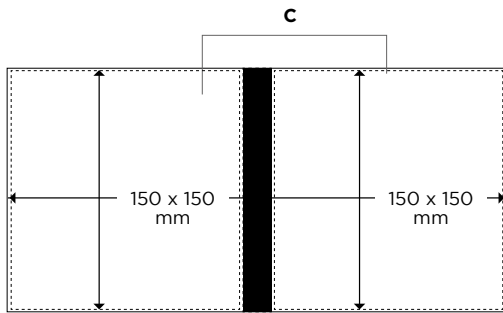
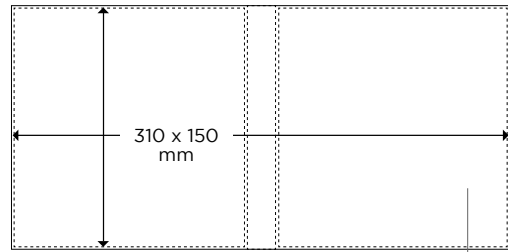
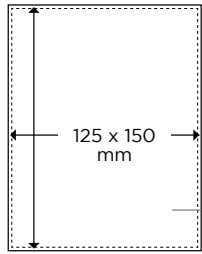

Combinaison de couleurs standards

Commande minimale 500u.

Corps

Opaque 01



Bouton

OPAQUE 01 03 07 18 02

GIVRÉ 69 63 71 66 68 67 40

Clip

OPAQUE 01 03 07 18 02

GIVRÉ 69 63 71 66 68 67 40

Section

OPAQUE 01 03 07 18 02

GIVRÉ 69 63 71 66 68 67 40

PU COVER NOTEBOOKS

209 BIC® Notebooks Dual A5

212 BIC® Notebooks Dual A6

MOLESKINE®

215 L'univers Moleskine

216 Carnets Classiques Pocket 9 x 14 cm

218 Carnets Classiques Large 13 x 21 cm

220 Carnets Classiques X-Large 19 x 25 cm

221 Cahier Journals

222 Special Products



Carnets

208 — 223

Démarquez-vous de la concurrence grâce à ce carnet de notes personnalisable et signé BIC® ! Créez le produit dont vous avez besoin pour chaque événement en combinant la couleur de la couverture en PU et celle des feuilles à l'intérieur. Le porte-stylo intégré est pratique pour avoir toujours votre stylo-bille BIC® avec vous.



Couverture - 3721(A5)/3725(A6)

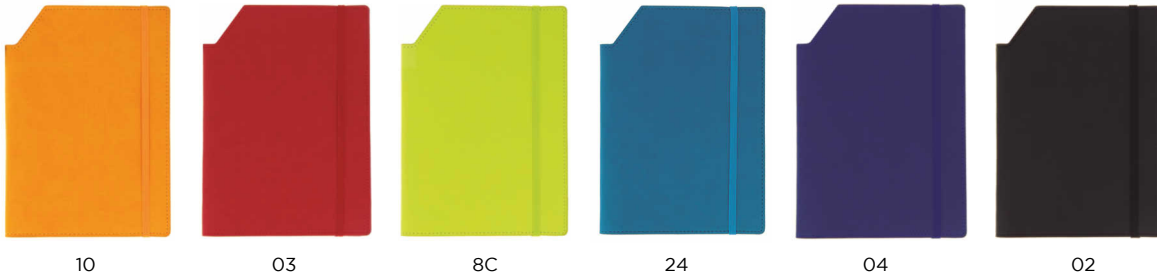

MIX & MATCH

Bloc-note intérieur - 3724(A5)/3712(A6)

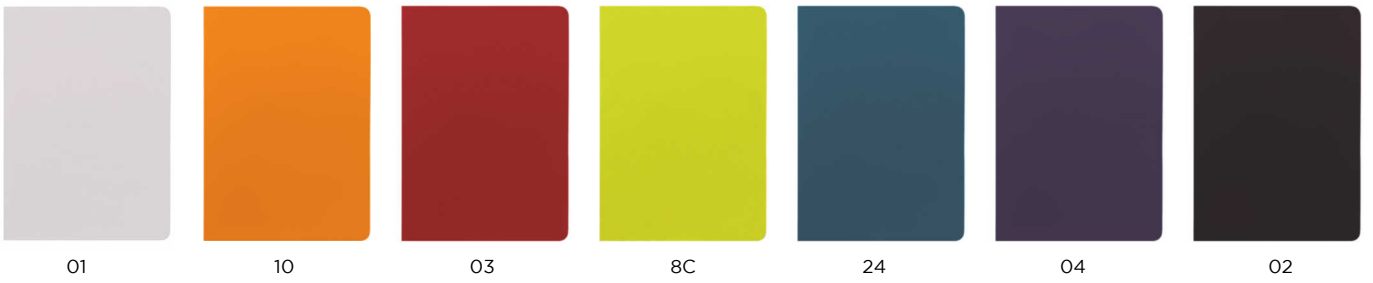

Créez votre propre combinaison :
choisissez la couleur de la couverture
et celle des carnets à l'intérieur.

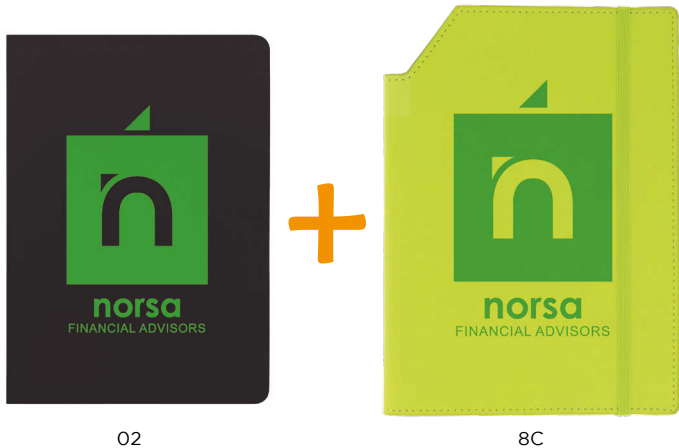

Commande minimale 50u.

Combinaison de couleurs standards



Couverture

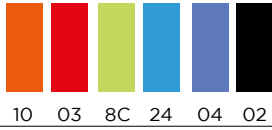

Bloc-note intérieur

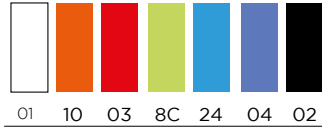

Créez votre propre combinaison :
choisissez la couleur de la couverture
et celle des carnets à l'intérieur.

Personnalisation :

BIC® NOTEBOOKS DUAL A5

Couverture 3721
A SP: max. 1 col.
B DB/HS: Film transparent
C SP: Couverture complète max. 1 col.

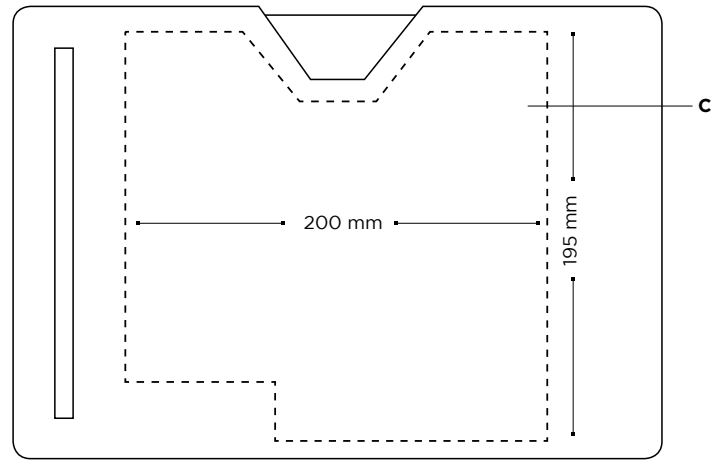
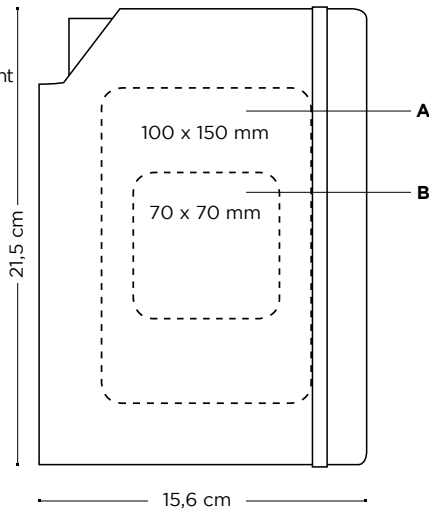

Type de papier :

- 80 Standard 80g
- 80 Standard 80g

Techniques d'impression :



(SP)
SÉRIGRAPHIE



(DB)
EMBOSSAGE
(HS)
EMBOSSAGE
COLORÉ

Emballage externe :



35 ± 8,6 Kg

Nouvel emballage spécial en option :



Gift Box A5 (Notebook + Ballpen)
+ INFO pag. 297

BIC® NOTEBOOKS DUAL A5 BLOC-NOTE INTÉRIEUR

Commande minimale 50u.

Utilisez le carnet de notes
à l'intérieur pour recharger votre Dual Cover,
ou en tant que bloc-notes !

Personnalisation :

Bloc-note intérieur 3724
D SP: max. 1 col.
E DB/HS: max. 1 col.

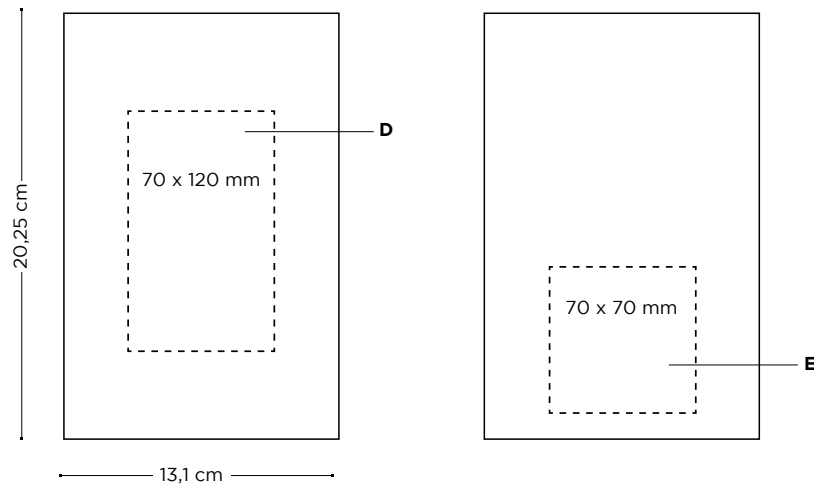

Type de papier :

- 80 Standard 80g
- 80 Standard 80g

Techniques d'impression :



Emballage externe :

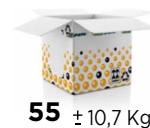

Commande minimale 50u.

Combinaison de couleurs standards



Couverture



10 03 8C 24 04 02

Bloc-note intérieur



01 10 03 8C 24 04 02

Créez votre propre combinaison :
choisissez la couleur de la couverture et
celle des carnets à l'intérieur.

Personnalisation :

BIC® NOTEBOOKS DUAL A6

Couverture 3725

A SP: max. 1 col.

B DB/HS: Film transparent

C SP: Couverture
complète max. 1 col.

Nouveau !

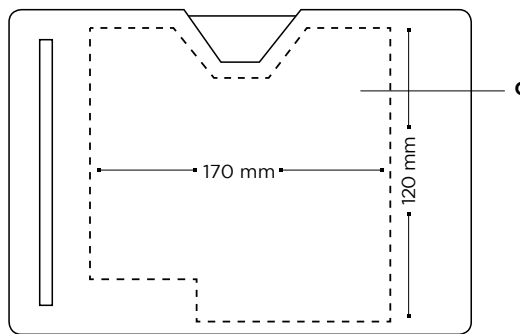
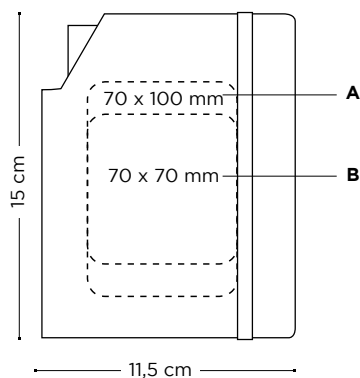

Nouvelle zone d'impression !

Ajoutez un stylo à bille BIC® à votre carnet BIC®



BIC® Media Clic



BIC® Super Clip



BIC® 4 Colours

① Prix sur demande.

Type de papier :

- 60 Standard 80g
- 60 Standard 80g

Techniques d'impression :



(SP)
SÉRIGRAPHIE



(DB)
EMBOSSAGE
(HS)
EMBOSSAGE
COLORÉ

Emballage externe :



35 ± 8,6 Kg

Nouvel emballage spécial
en option :



Gift Box A6 (Notebook + Ballpen)
+ INFO pag. 297

BIC® NOTEBOOKS DUAL A6 BLOC-NOTE INTÉRIEUR

Commande minimale 50u.

Utilisez le carnet de notes à l'intérieur
pour recharger votre Dual Cover,
ou en tant que bloc-notes !

Personnalisation :

Bloc-note intérieur 3712

D SP: max. 1 col.

E DB/HS: max. 1 col.

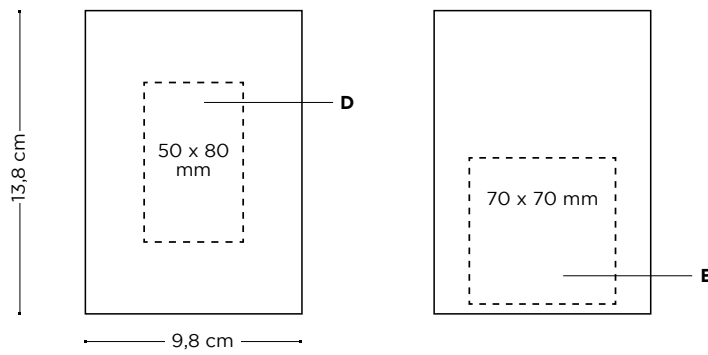

Type de papier :

- 60 Standard 80g
- 60 Standard 80g

Techniques d'impression :



(SP)
SÉRIGRAPHIE



(DB)
GAUFRAGE



(HS)
MARQUAGE À
CHAUD

Emballage externe :



55 ± 10,7 Kg

MOLESKINE



Moleskine propose des objets fonctionnels simples, intelligents, qui peuvent devenir des outils de communication puissants pour votre marque. Racontez votre histoire.



UNE MARQUE EMBLÉMATIQUE

La force internationale de Moleskine vient des liens continus que nous entretenons avec le monde de l'art et de la culture, sans oublier une communauté créative active dans le monde entier. C'est une marque nomade, diversifiée et de grande qualité qui permet d'allier mobilité et vie quotidienne. **Les valeurs de la marque reposent sur ces cinq piliers :**



CULTURE

Moleskine est une **icône culturelle**, une marque qui raconte une histoire. Un objet Moleskine relie son propriétaire à tout un héritage artistique, littéraire et culturel et à une tradition d'exploration géographique.

MÉMOIRE

Moleskine est une marque attachée à la collecte de souvenirs et à **l'organisation du temps** et des priorités dans notre vie professionnelle et nos loisirs.

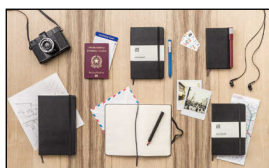
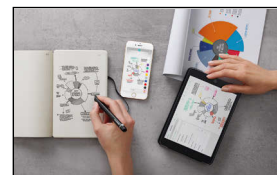

VOYAGE

Célébrant le **nomadisme contemporain**, Moleskine offre toute une gamme d'outils qui vous accompagneront dans vos voyages, ordinaires ou extraordinaires.

IMAGINATION

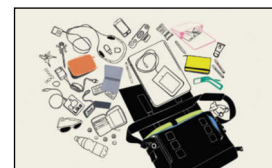

Les collections Moleskine accompagnent toutes les expériences de vie qui comptent et offrent un **espace ouvert à la créativité**.



IDENTITÉ PERSONNELLE

Un objet Moleskine devient **partie intégrante de la personnalité de chacun**. C'est un accessoire basique, compact et intelligent. En associant éléments pratiques et symboliques, il permet de conserver l'énergie et les émotions collectées au fil du temps.

MOLESKINE CARNETS CLASSIQUES
POCKET 9 X 14 CM

Couverture Rigide - 15054  / 15055 

Couverture Souple - 15096 

*Classique et
élégant*



30



30

*Un carnet de poche,
un format idéal
à emporter partout !*



Couverture Rigide - 15054 



10

20

52

30

Couverture Rigide - 15054 

Couverture Souple - 15096 



30



30

*Personnalisez la bande
de papier*



Autres options disponibles sur demande

Commande minimale 25u.

Personnalisation :

POCKET COUVERTURE RIGIDE

15054/15055

A SP: max. 1 col.

B DB/HS: max. 1 col.

C BP: Quadrichromie

D SP: max. 2 col.

E SP: Bandeau papier extérieur, CMYK

Egalement disponible en taille moyenne - 15107**
11,5 x 18 cm

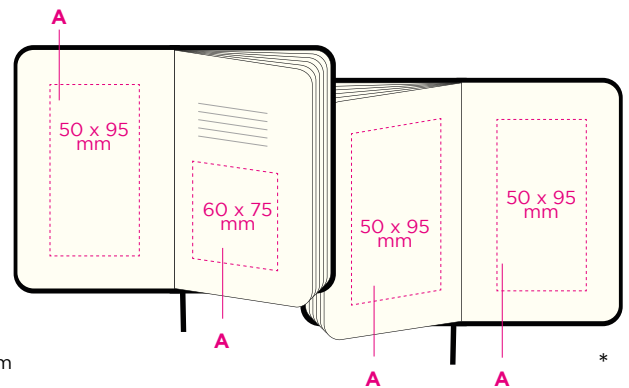
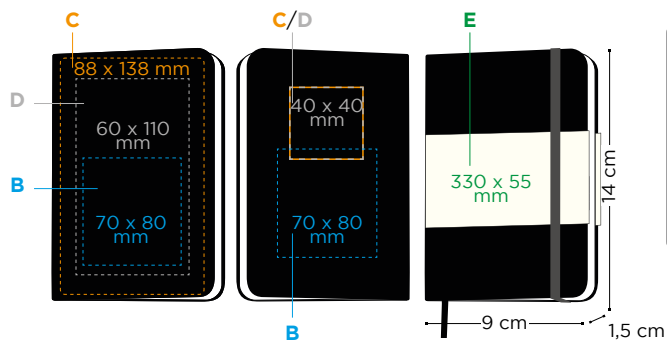

Personnalisation :

POCKET COUVERTURE SOUPLE

15096

A SP: max. 1 col.

B DB/HS: max. 1 col.

C SP: Bandeau papier extérieur, CMYK

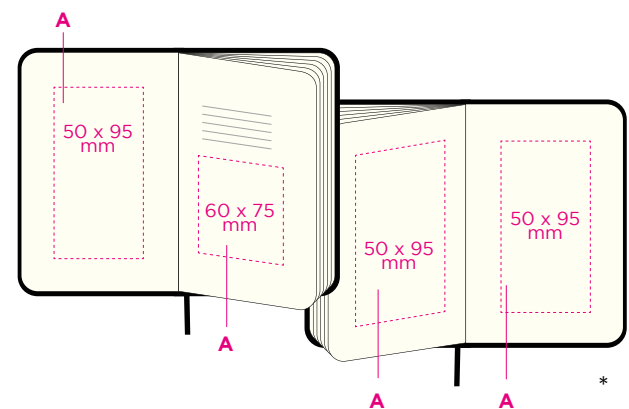
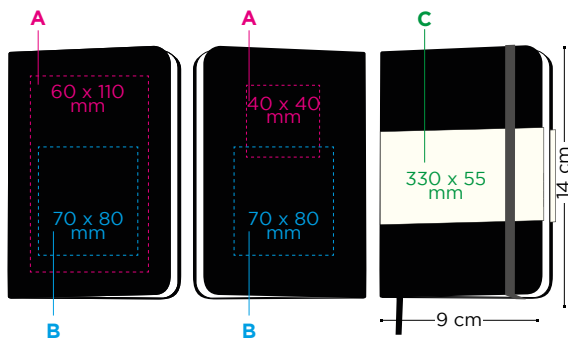

Type de papier :

- 192 15054/15096
- 192 15054

Techniques d'impression :

(SP) SÉRIGRAPHIE	(DB) GAUFRAGE	(HS) MARQUAGE À CHAUD	(DG) QUADRICHROMIE	(BP) britePix™

*La position ou la hauteur de la zone de marquage peut varier. Nous consulter.

**Consultez cette option

MOLESKINE CARNETS CLASSIQUES

LARGE 13 X 21 CM

Couverture Rigide - 15056 

Couverture Souple - 15065 



30



30

Couverture Rigide - 15056 



Couverture Rigide - 15056 



Couverture Souple - 15065 



Autres options disponibles sur demande

Commande minimale 25u.

Personnalisation :

LARGE COUVERTURE RIGIDE

15056/15057

A SP: max. 1 col.

B DB/HS: max. 1 col.

C BP: Quadrichromie

D SP: max. 2 col.

E SP: Bandeau papier extérieur, CMYK

Egalement disponible avec les pages supplémentaires pour plus d'histoires à raconter! Cahier rallongé - 15105

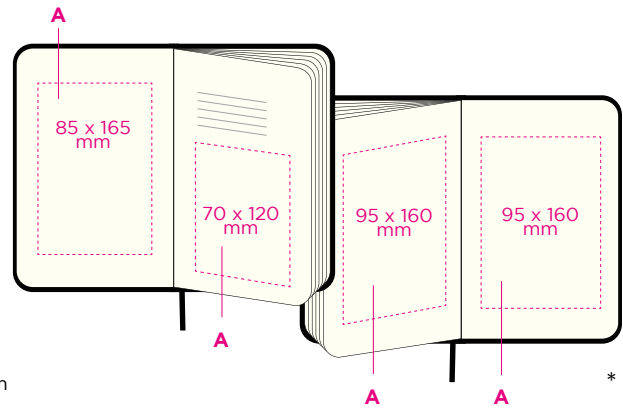
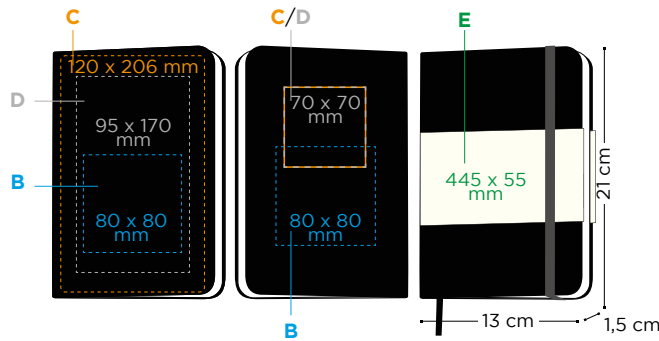

Personnalisation :

LARGE COUVERTURE SOUPLE

15065

A SP: max. 1 col.

B DB/HS: max. 1 col.

C SP: Bandeau papier extérieur, CMYK

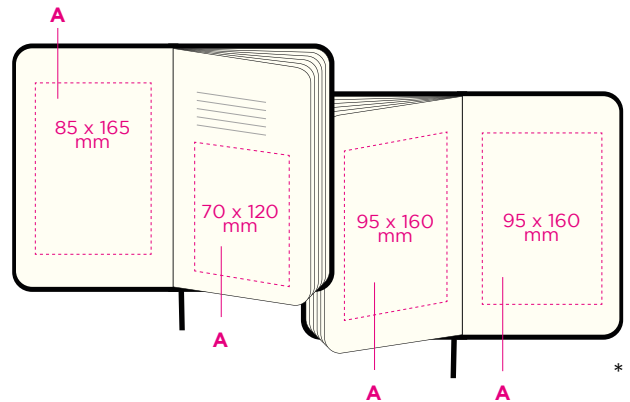
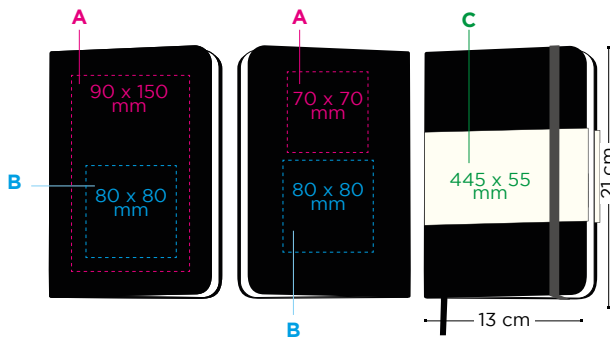

*La position ou la hauteur de la zone de marquage peut varier. Nous consulter.

Type de papier :

- 192 15065
- 240 15056
- 400 15105

Techniques d'impression :

- (SP) SÉRIGRAPHIE
- (DB) GAUFRAGE
- (HS) MARQUAGE À CHAUD
- (DG) QUADRICHROMIE

Nouvel emballage spécial en option :

- (BP) britePix™



Giftbox for notebook + ballpen

12017 for hard cover
12016 for soft cover
Consultez cette option
Prix sur demande

www.bicgraphic.eu

MOLESKINE CARNETS CLASSIQUES

X-LARGE 19 X 25 CM

Couverture Rigide - 15097 

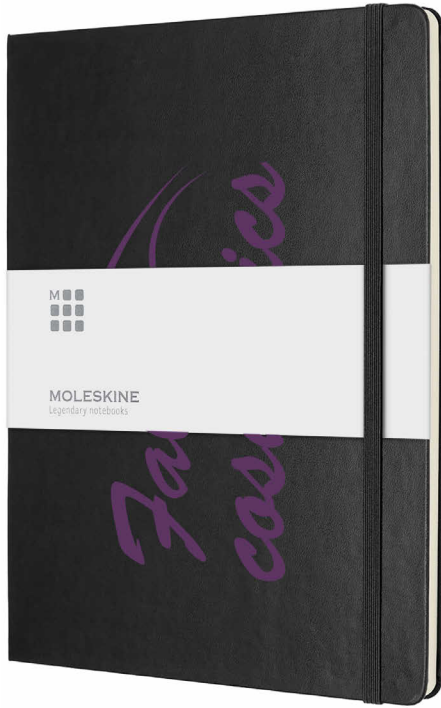

30

Couverture Souple - 15094 



30

*Format X-Large
pour vos plus
grandes idées !*

Commande minimale 25u.

Personnalisation :

- A SP:** max. 2 col.
- B SP:** max. 1 col.
- C DB/HS:** max. 1 col.
- D SP:** Bandeau papier extérieur, CMYK

X-LARGE COUVERTURE RIGIDE / SOUPLE

15097/15094

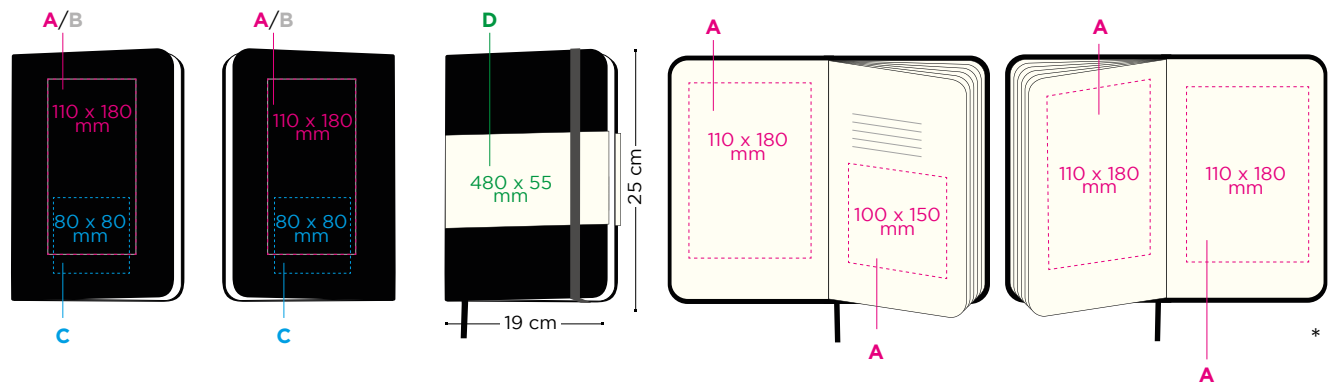

Type de papier :

192  15097/15094

Techniques d'impression :

-  (SP) SÉRIGRAPHIE
-  (DB) GAUFRAGE
-  (HS) MARQUAGE À CHAUD
-  (DG) QUADRICHROMIE

*La position ou la hauteur de la zone de marquage peut varier. Nous consulter.

Autres options disponibles sur demande

MOLESKINE CAHIER JOURNALS

Pocket - 15076 

Couverture en carton!



30



42

Commande minimale 100u.

Personnalisation :

POCKET

15076

A SP: max. 1 col.

B DB/HS: max. 1 col.

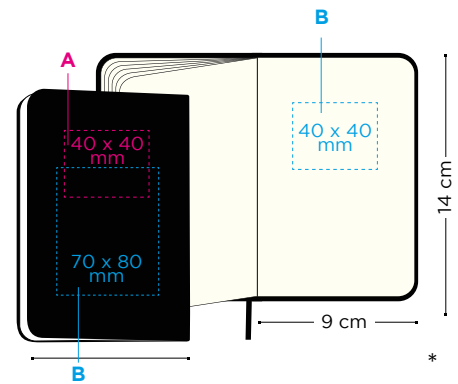
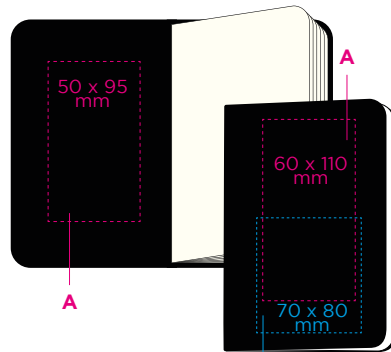

large - 15067 

16 dernières feuilles détachables

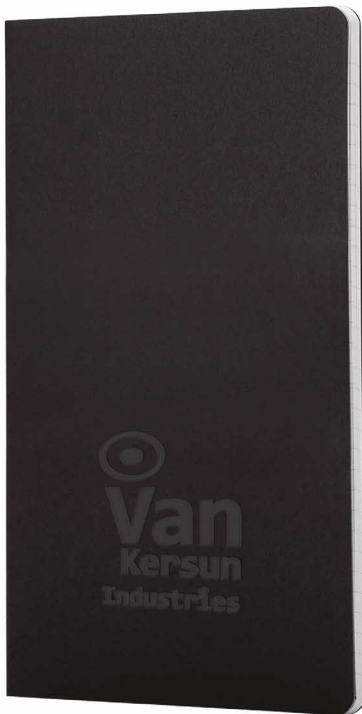

30



42



4X

LARGE

15067

A SP: max. 1 col.

B DB/HS: max. 1 col.

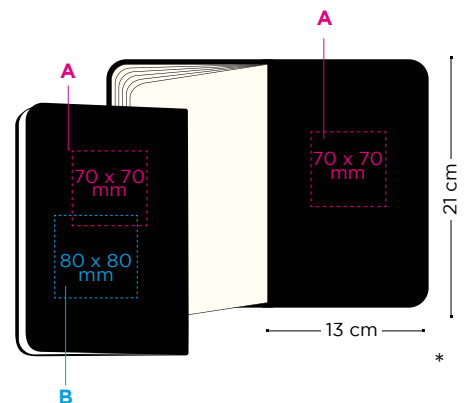
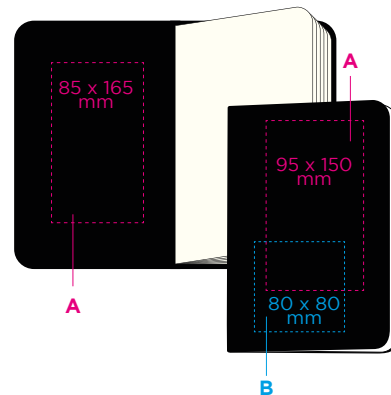

Type de papier :

64  15076

80  15067

Techniques d'impression :



(SP) SÉRIGRAPHIE



(DB) GAUFRAGE



(HS) MARQUAGE À CHAUD

*La position ou la hauteur de la zone de marquage peut varier. Nous consulter.

Autres options disponibles sur demande

CARNETS PASSION Un cadeau unique pour vos centres d'intérêt

5109

5113

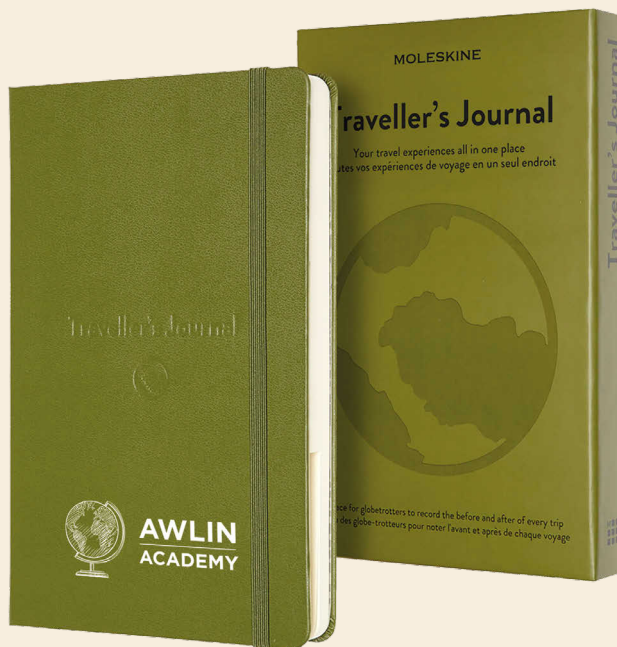
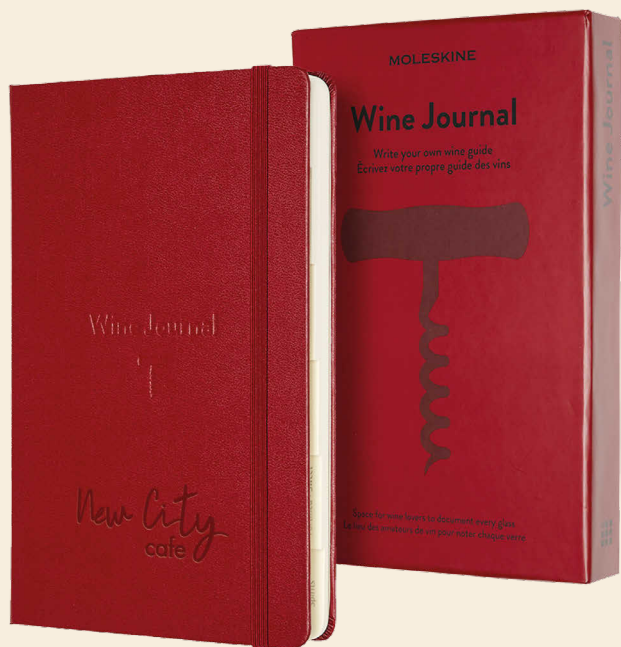

Commande minimale 16u.

Personnalisation :

15109/15113

A SP: max. 1 col.

B DB/HS: max. 1 col.

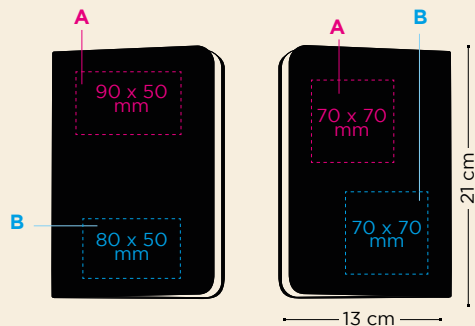

CARNET PASSION - VIN
Écrivez votre propre guide des vins.

CARNET VINS



CARNET PASSION - VOYAGE
Toutes vos expériences de voyage en un seul endroit.

CARNET VOYAGES

Autres options sur demande

Type de papier :

400 Papier 70 g/m²

Smart Writing System - 15104

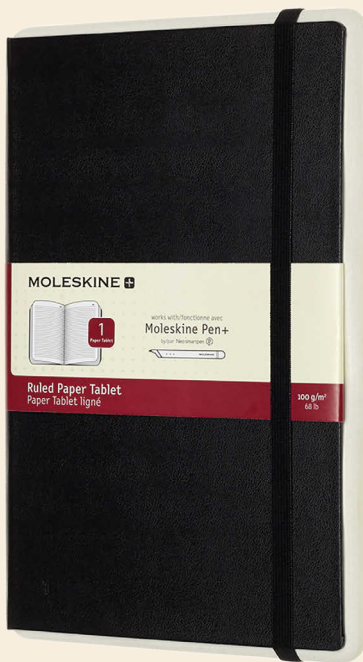

Commande minimale 1u.

Personnalisation :

15104

A BP: Quadrichromie

B DB/HS: max. 1 col.

C SP: max. 1 col.

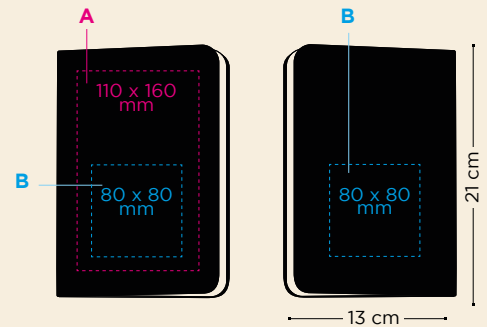

Type de papier :

176

Avec l'Appli Moleskine Notes, ces outils intelligents permettent à vos notes et à vos pensées écrites à la main de sortir de la page et d'évoluer sur l'écran en temps réel.



30

Découvrez comment cela fonctionne.

Sac à Dos Business - 15018



Commande minimale 8u.

Personnalisation :

15104

SP: max. 1 col.



Votre espace de travail mobile.
Augmentez la productivité en déplacement.

BRIQUETS

- 230** BIC® J25 Lighter
- 234** BIC® J23 Lighter
- 238** BIC® J26 Lighter
- 242** BIC® J38 Lighter
- 246** BIC® J39 Lighter
- 250** BIC® Mega Lighter

COQUES DE BRIQUETS

- 252** BIC® Styl'it Luxury Case
- 254** BIC® Aluminium Flat Case
- 255** BIC® Clip Case
- 256** BIC® 3D Case

AUTRES PRODUITS

- 257** BIC® Pocket Ashtray



Briquets

226 — 259

LA SÉCURITÉ, NOTRE PRIORITÉ

FLAMME STABLE
Grâce à l'isobutane pur



CAPOT DE SÉCURITÉ
Fabriqué en acier résistant
avec verrouillage de sécurité



HAUTE RÉSISTANCE
Réservoir fabriqué
avec une résine
technique (Delrin®) à
haute résistance
mécanique



BIC J26 LIGHTER

SÉCURITÉ ENFANTS*
Conforme à la norme
EN 13869

* Un briquet "sécurité enfants" n'est pas un briquet exempt de tout risque pour les enfants: c'est un briquet que 85% au moins des enfants de moins de 51 mois ne peuvent pas faire fonctionner, ce qui implique que la proportion des enfants en cause capables de l'actionner peut aller jusqu'à 15%. Les adultes doivent donc toujours veiller à ce que les briquets soient hors de portée des enfants, même s'il s'agit de briquets « sécurité enfants ».



BRIQUET LONGUE DURÉE

Grâce au plus grand
volume de gaz dans le
réservoir:
**JUSQU'À 3000
ALLUMAGES**



BIC® BRIQUETS

NOTRE QUALITÉ. VOTRE SÉCURITÉ

BIC MEGA LIGHTER



50%

BIC J26 DIGITAL LIGHTER

BIC J38 DIGITAL LIGHTER

BIC J23 DIGITAL LIGHTER

BIC J25 DIGITAL LIGHTER



Jusqu'à 1400 allumages



Jusqu'à 1800 allumages



Jusqu'à 3000 allumages



Jusqu'à 1800 allumages

BIC J39 DIGITAL LIGHTER



Jusqu'à 1050 allumages

Jusqu'à 750 allumages

FINITIONS NUMÉRIQUES ET TEXTURES



DIGITAL BRILLIANT DIGITAL MATT

Brillante ou mate ?

Choisissez la finition qui vous plaît !



METALLIC

Créez de superbes effets !
Effets métalliques sur les textes, les images et le fond.



HOLOGRAPHIC GOLD HOLOGRAPHIC SILVER

Démarquez-vous de la concurrence ! Jouez avec de **jolis reflets légers de couleurs** en utilisant la finition holographique.



IMPRESSION PUFFY

Faites preuve d'originalité !

Faites ressortir votre marque grâce à notre encre « puffy » et donnez ainsi du relief à votre logo.



UV PRINTING

Faites ressortir votre marque avec une finition très brillante ! Combinez les finitions mates et brillantes pour souligner les contrastes et faire ressortir le motif sur **fond mat.**



SANDY

Créez un **effet « papier de verre »** grâce à une surface granuleuse.



PUFFY GLITTER

Admirez et touchez la **texture colorée à paillettes !**



GLOW IN THE DARK

Faites briller votre marque, **même dans le noir !**





Le célèbre briquet BIC®, une icône indémodable, avec un design toujours tendance ! 3 tailles différentes et une vaste gamme de combinaisons de couleurs.





2360

Nouvelle couleur !



01

57

100%

57

57

06

Disponible en *britePix*

Nouvelle couleur ! 57

Nouvelle couleur !



8G

03

5C

100%

59

24

04

25

25

Disponible en *britePix*

Pastel - 2360

2360

Gold Hood
2430

All Black
2364



90

84

85

100%

83

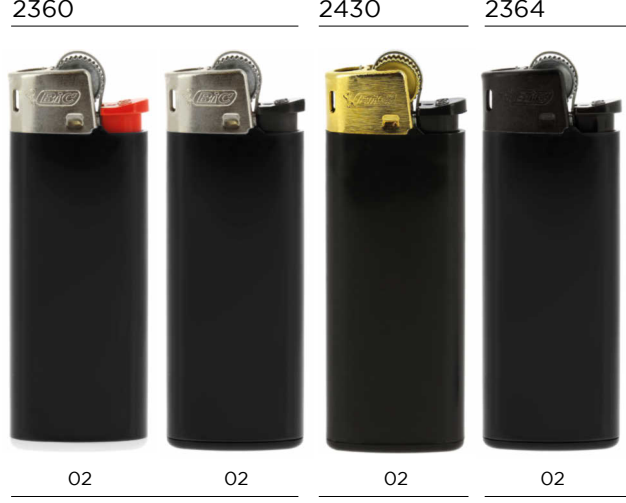

02

02

02

02

Disponible en *britePix*

*48h non disponibles pour les finitions digital

Disponible en *britePix*

Disponible en *britePix* Disponible en *britePix*

Commande minimale 300u.

Personnalisation :

BIC® J25 LIGHTER

2360/2364/2430

A/C SP: max. 4 col.

BIC® J25 LIGHTER *britePix*

2360/2364/2430

A/C BP: Numérique

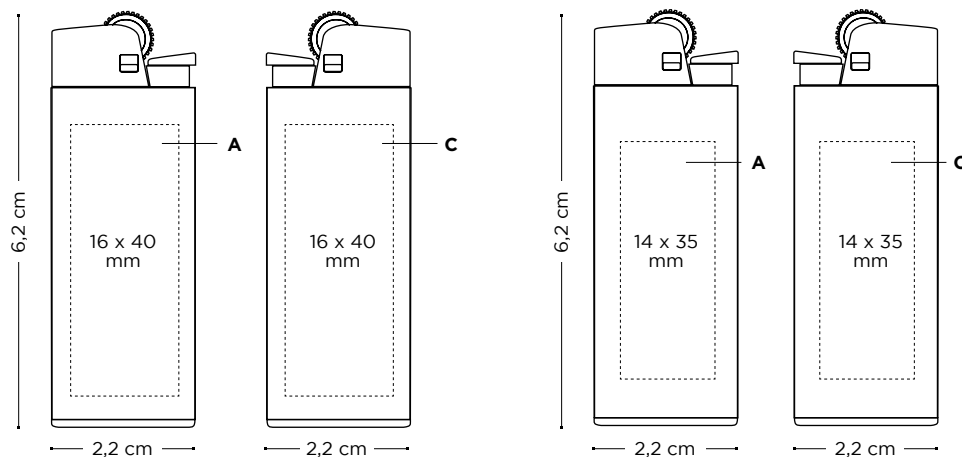

Jusqu'à 1400
allumages

Conform
EN 13869

85%
CONFORM
ISO 9994

Emballage :



Emballage standard :
plateau de 50 u.

Techniques d'impression :



(SP)
SÉRIGRAPHIE



(BP) *britePix*™



Emballage externe :



300 ± 3,8 Kg



Pastel
FABRIQUÉ
EN FRANCE



FABRIQUÉ
EN ESPAGNE





Impression numérique !

BIC® J25 DIGITAL LIGHTER
2360



BR PUFFY



MATT M



MATT PUFFY



MATT PUFFY



BR



MATT UV

Commande minimale 600u.

Personnalisation :

BIC® J25 DIGITAL LIGHTER

2360

A DG: Numérique

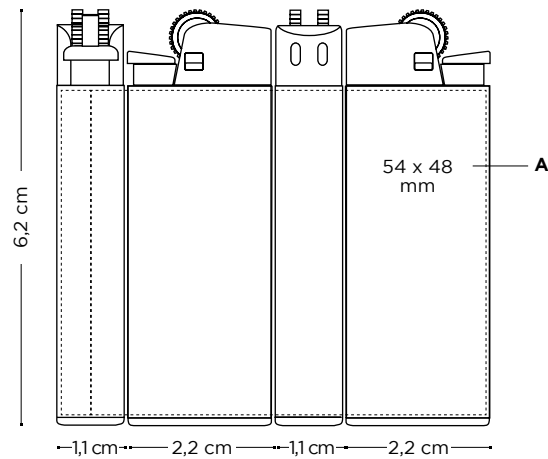

	Finitions numérique	Commande minimale
	Brilliant ou matt	600 u.
	Holographic	600 u.
	Impression Puffy	5.100 u.
	Metallic	50.000 u.
	UV printing	5.100 u.
	Sandy	5.100 u.
	Puffy glitter	5.100 u.
	Glow in the dark	5.100 u.

① Prix sur demande.

Jusqu'à 1400 allumages

Conform EN 13869 85% CONFORM ISO 9994

Emballage :



Emballage standard : plateau de 50 u.

Techniques d'impression :



(DG) NUMÉRIQUE

Emballage externe :



600 ± 7,6 Kg



FABRIQUÉ EN ESPAGNE



compact, il se glisse partout !



Nouvelle couleur !

2340



57

12

100%

03

5C

10



59

05

24

04

25

02

*48h non disponible en impression numérique

Commande minimale 300u.

Personnalisation :

BIC® J23 LIGHTER

2340

A/C SP: max. 4 col.

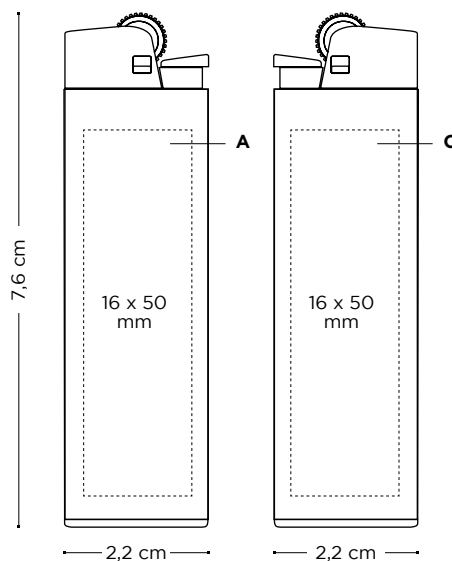

Jusqu'à 1800
allumages



Emballage :



Emballage standard :
plateau de 50 u.

Techniques d'impression :



(SP)
SÉRIGRAPHIE

Emballage externe :



600 ± 9,5 Kg



FABRIQUÉ
EN FRANCE



Impression numérique !

BIC® J23 DIGITAL LIGHTER
2340



MATT M



MATT PUFFY UV



BR PUFFY

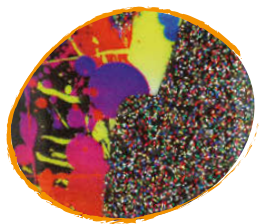

BR PUFFY GUMMI



BR

Commande minimale 600u.

Personnalisation :

BIC® J23 DIGITAL LIGHTER

2340

A DG: Numérique

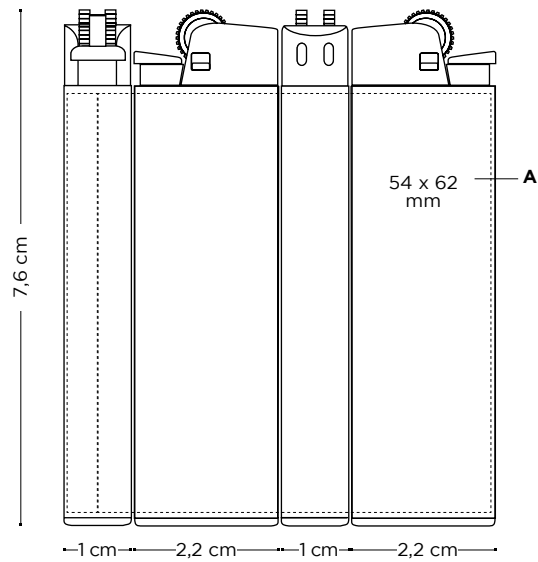

Jusqu'à 1800
allumages 

Conform
EN 13869 

CONFORM
ISO 9994

Emballage :



Emballage standard :
plateau de 50 u.

Techniques d'impression :



(DG)
NUMÉRIQUE

Emballage externe :



600 ± 9,5 Kg



FABRIQUÉ
EN FRANCE



Longue durée : jusqu'à 3 000 allumages



2320



01

57

8G

10

03

Nouvelle couleur !



59

24

25

06

02

100%

*48h non disponible en impression numérique

Commande minimale 300u.

Personnalisation :

BIC® J26 LIGHTER

2320

A/C SP: max. 4 col.

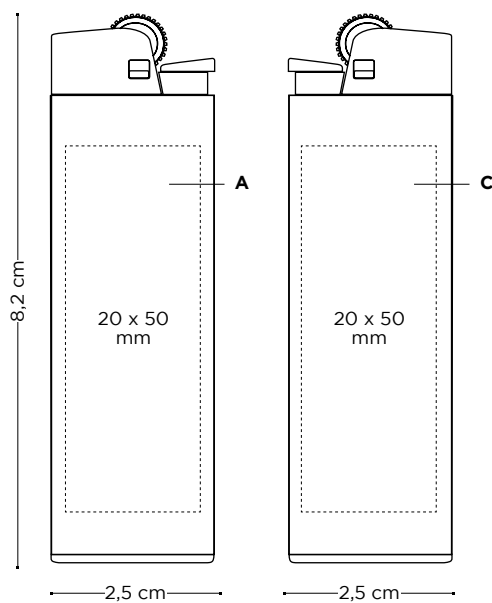

Jusqu'à 3000
allumages 

Conform
EN 13869  85% 

CONFORM
ISO 9994

Emballage :



Emballage standard :
plateau de 50 u.

Techniques d'impression :



(SP)
SÉRIGRAPHIE

Emballage externe :



600 ± 15,1 Kg



FABRIQUÉ
EN ESPAGNE



Impression numérique !

BIC® J26 DIGITAL LIGHTER
2320



MATT M PUFFY



BR H

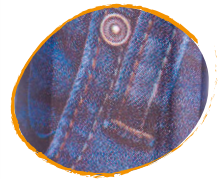

BR M



MATT



MATT UV



MATT M

Commande minimale 600u.

Personnalisation :

BIC® J26 DIGITAL LIGHTER

2320

A DG: Numérique

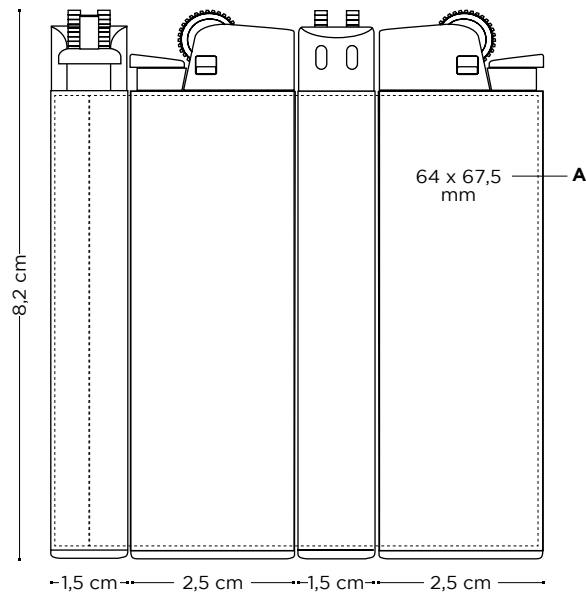

Finitions numériques - coût supplémentaire

Commande minimale

	Brilliant ou matt	600 u.
	Holographic	600 u.
	Impression Puffy	5.100 u.
	Metallic	50.000 u.
	UV printing	5.100 u.
	Sandy	5.100 u.
	Puffy glitter	5.100 u.
	Glow in the dark	5.100 u.

Les prix incluent l'impression numérique sur le corps.

① Prix sur demande.

Jusqu'à 3000 allumages

Conform EN 13869 CONFORM ISO 9994

Emballage :



Emballage standard : plateau de 50 u.

Techniques d'impression :



(DG) NUMÉRIQUE

Emballage externe :



600 ± 15,1 Kg



FABRIQUÉ EN ESPAGNE



Allumage élégant et confortable!

Standard - 2452

Gold Hood - 2451



57



57



57

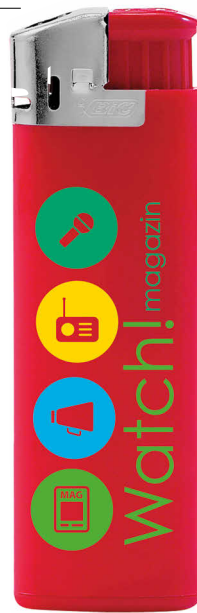

03

100%



25



02



02

*48h non disponible en impression numérique



Commande minimale 300u.

Personnalisation :

BIC® J38 LIGHTER

2452/2451

A/B SP: max. 4 col.

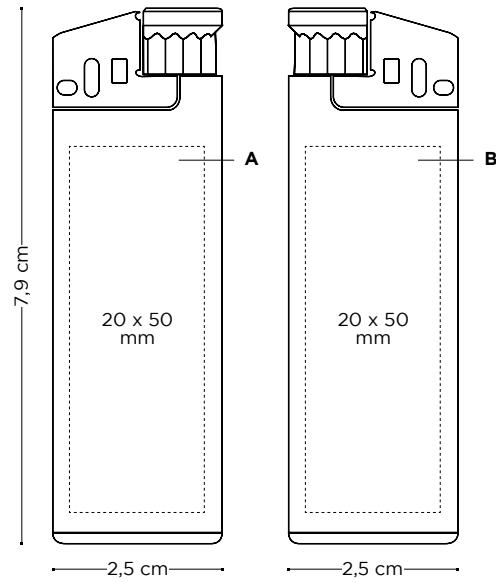

Jusqu'à 1800
allumages



Conform
EN 13869

85%
♻️

CONFORM
ISO 9994

Emballage :



Emballage standard :
plateau de 50 u.

Techniques d'impression :



(SP)
SÉRIGRAPHIE

Emballage externe :



600 ± 13,2 Kg



FABRIQUÉ
EN ESPAGNE



Impression numérique !

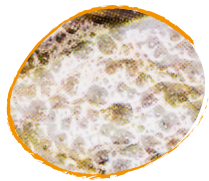

BR SA

BIC® J38 LIGHTER DIGITAL
Standard - 2452



57



57 BR

360°

100%



57

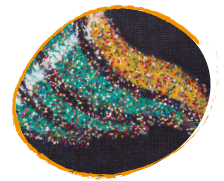

BR PUFFY GLITTER



BR GLOW



MATT M

Commande minimale 600u.

Personnalisation :

BIC® J38 DIGITAL LIGHTER

2452

A DG: Numérique

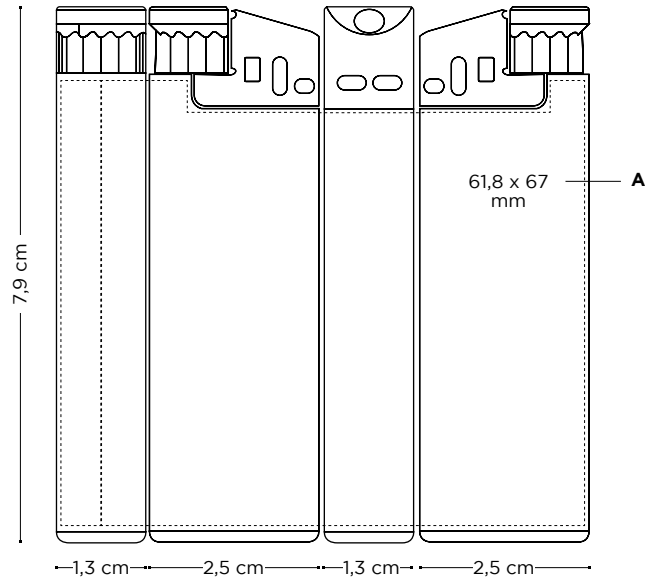

Jusqu'à 1800
allumages



Conform
EN 13869

85%
Recyclé

CONFORM
ISO 9994

Emballage :



Emballage standard :
plateau de 50 u.

Techniques d'impression :



(DG)
NUMÉRIQUE

Emballage externe :



600 ± 13,2 Kg



FABRIQUÉ
EN ESPAGNE



Taille mini pratique!

Standard - 2479



57



57



57



03



25

100%



02

*48h non disponible en impression numérique

Commande minimale 300u.

Personnalisation :

BIC® J39 LIGHTER

2479

A/B SP: max. 4 col.

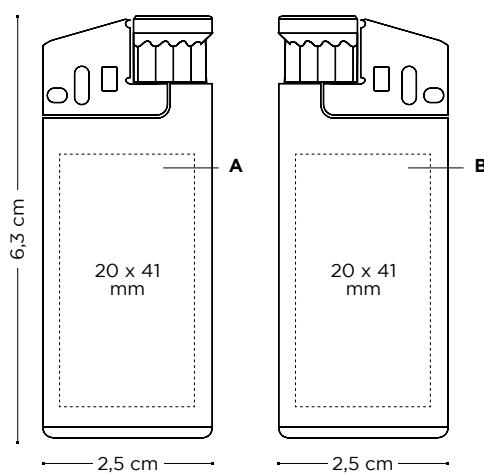

Jusqu'à 1050
allumages



Emballage :



Emballage standard :
plateau de 50 u.

Techniques d'impression :



(SP)
SÉRIGRAPHIE

Emballage externe :



600 ± 11,1 Kg



FABRIQUÉ
EN ESPAGNE



MATT SA

BIC® J39 LIGHTER DIGITAL
Standard - 2479

Impression numérique !



57



03 BR



57



MATT M

360°

100%



BR



BR GLOW

Commande minimale 600u.

Personnalisation :

BIC® J39 DIGITAL LIGHTER

2479

A DG: Numérique

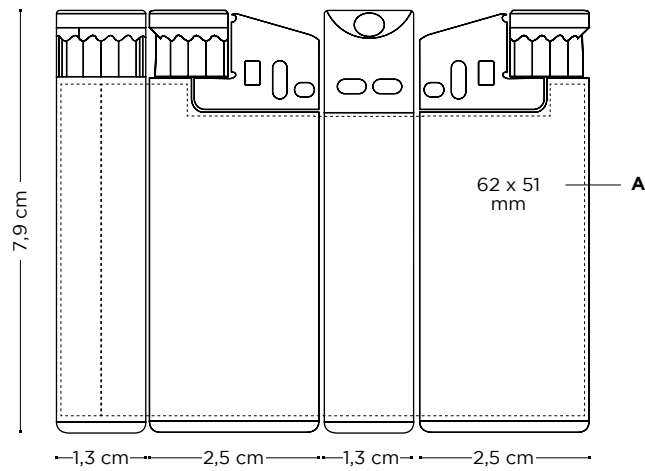

Jusqu'à 1050
allumages



Conform
EN 13869

95%
Recyclé

CONFORM
ISO 9994

Emballage :



Emballage standard :
plateau de 50 u.

Techniques d'impression :



(DG)
NUMÉRIQUE

Emballage externe :



600 ± 11,1 Kg



FABRIQUÉ
EN ESPAGNE

simple et pratique à utiliser grâce
à son bec de 6 cm



2500 - 01

Nouvelle couleur !



2500 - 03

100%



Proposé en emballage individuel !
Personnalisez-le à partir de 2500 unités.



Commande minimale 100u.

boîte carton individuelle:



Personnalisation :

BIC® MEGA LIGHTER
2500

A PD: max. 2 col. **B PD:** max. 2 col. **B BP:** Quadrichromie **C DG:** Numérique
BP Texture: Quadrichromie

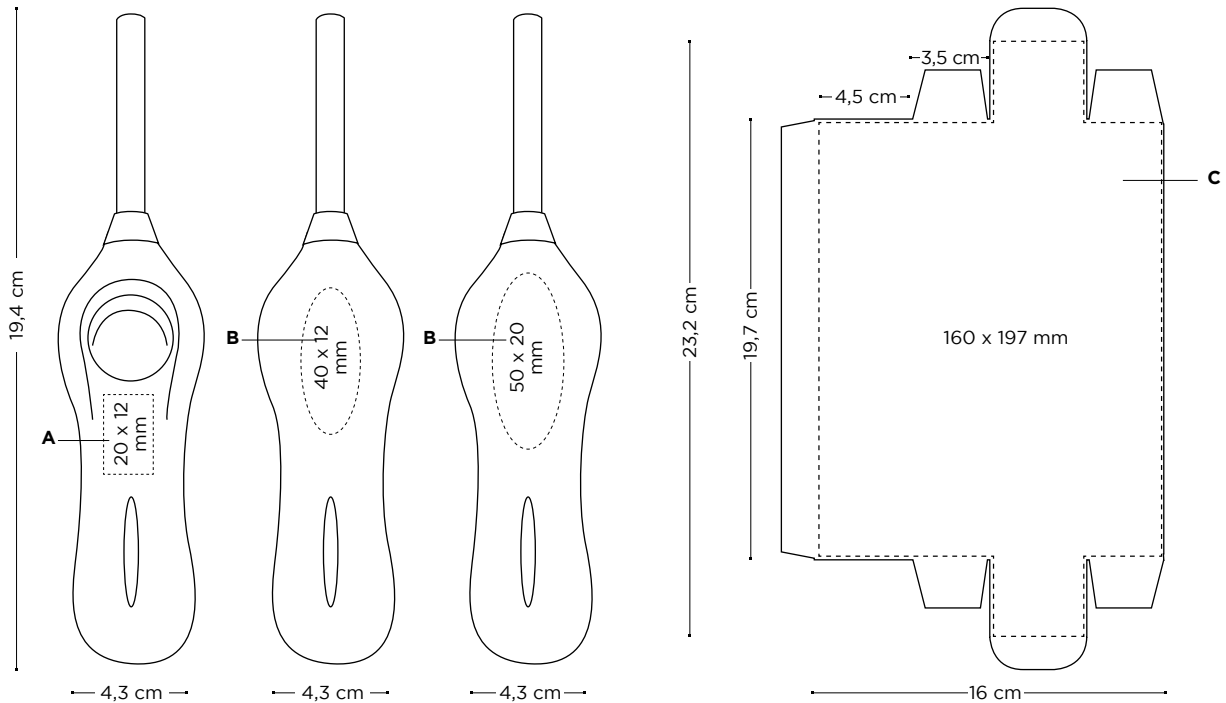

Jusqu'à 750 allumages



Conform ISO 22702

Emballage :



Emballage standard :
boîte carton individuelle

Techniques d'impression :



(PD)
TAMPOGRAPHIE



(BP)
britePix™



(DG)
NUMÉRIQUE



Emballage externe :



100 ± 8,3 Kg

2386



01

47

100%

Neon - 2386



2F

1G

5C

59

100%

Commande minimale 100u.

Personnalisation :

BIC® STYL'IT LUXURY CASE
2386

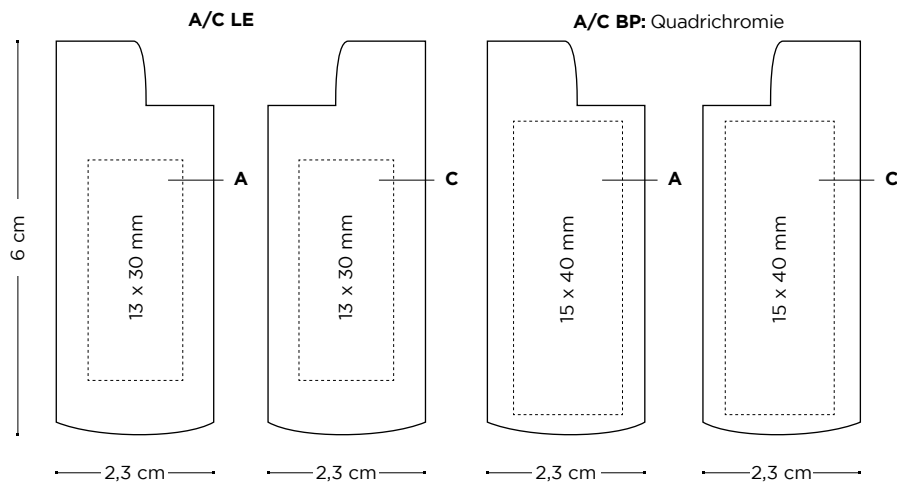

Emballage :



Emballage standard :
boîte de 10 unités

Techniques d'impression :



(LE)
LASER



(BP)
britePix™



Emballage externe :



300 ± 6,1 Kg

Soft - 2153



01

47



25

02

Métallique - 2161



47

02

Commande minimale 100u.

Personnalisation :

BIC® STYL'IT LUXURY CASE
2153/2161
A/C LE

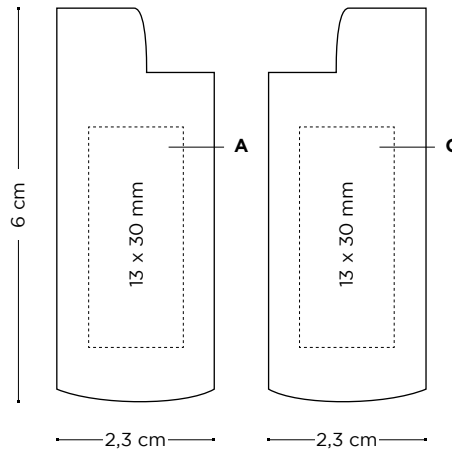

Emballage :



Emballage standard :
boîte de 10 unités

Techniques d'impression :



Emballage externe :



300 ± 6,1 Kg

3 faces personnalisables !

2156



01

47

03

07

02

Commande minimale 100u.

Personnalisation : BIC® ALUMINIUM FLAT CASE
2156

Nouveau ! A/C PD: max. 1 col.

A/B/C BP: Quadrichromie

A/B/C LE

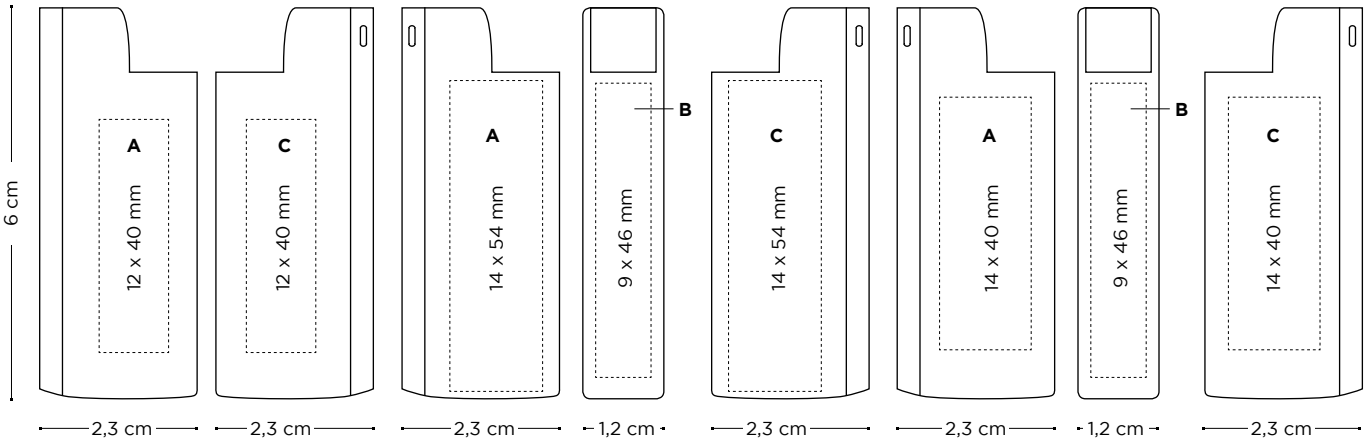

Prix (€)

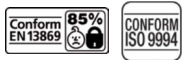

Emballage :



Emballage standard :
boîte de 10 unités

Techniques d'impression :



(PD)
TAMOGRAPHIE



(LE)
LASER



(BP) britePix™



Emballage externe :



300 ± 6,9 Kg

2398

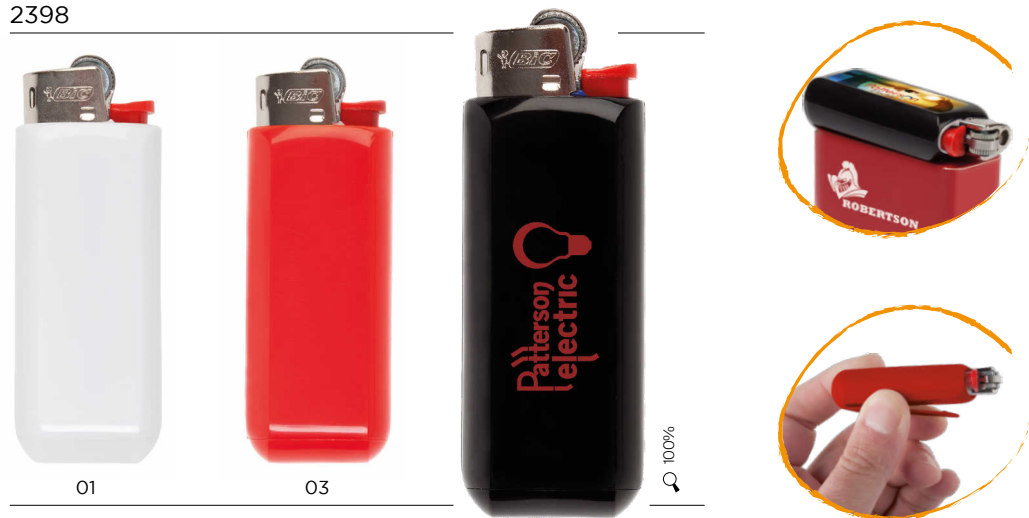

01

03

02

Commande minimale 100u.

Personnalisation: **BIC® CLIP CASE**
2398

A/C PD: max. 1 col.

A/C BP: Quadrichromie
BP Texture: Quadrichromie

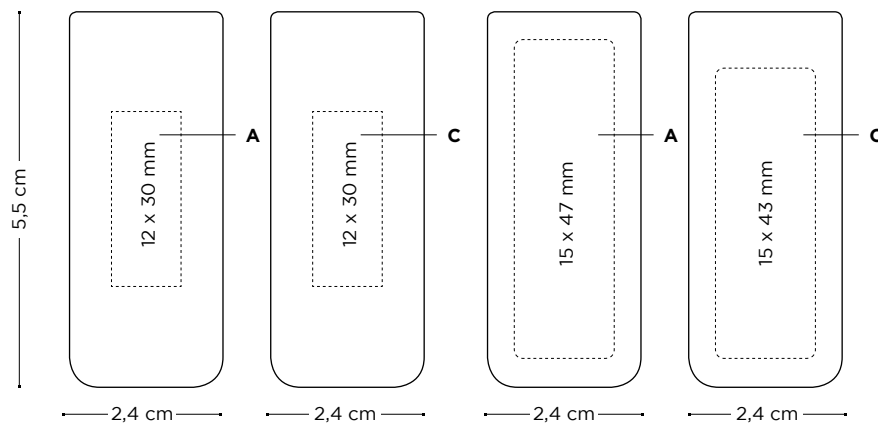

Prix (€)



Emballage :



Emballage standard :
boîte de 10 unités

Techniques d'impression :



(PD)
TAMPOGRAPHIE



(BP) britePix™



Emballage externe :



300 ± 7,5 Kg

Convertissez votre logo en 3D !

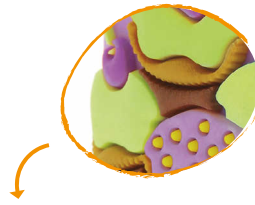

2395



Commande minimale 1.200u.

Personnalisation :

BIC® 3D CASE

2395

A/C 3D: max. 6 col.

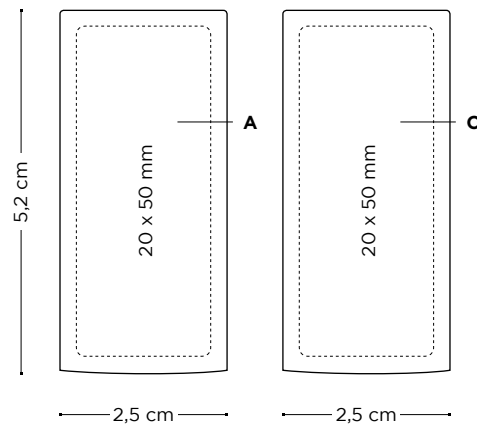

Pour de plus amples détails, veuillez contacter notre service clients.

Emballage :



Emballage standard :
boîte de 50 unités

Techniques d'impression :



Embossage 3D

Emballage externe :



300 ± 7,5 Kg



Personnalisation : BIC® POCKET ASHTRAY
Commande minimale 5.000u.
 3850 (2 couleurs max. Pour les commandes inférieures à 20.000u)
A SP: max. 5 col.

BIC® POCKET ASHTRAY KRAFT
Commande minimale 10.000u.
 3851
A SP: max. 2 col.

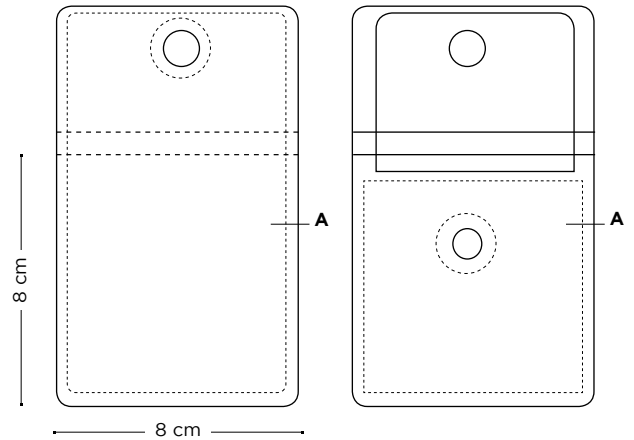
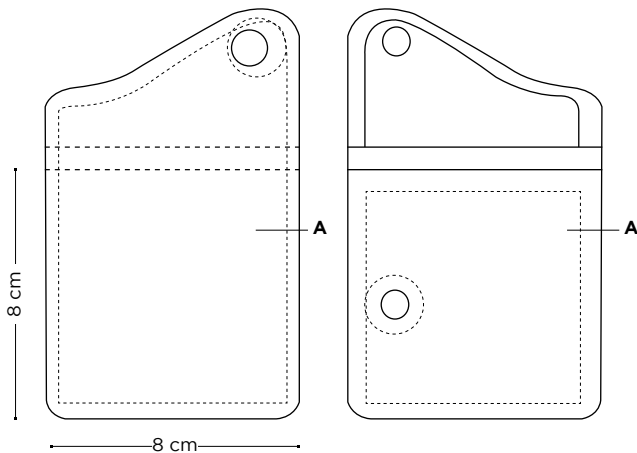

Emballage :



Boîte de 10 unités. Chaque BIC® Pocket Ashtray est mis sous emballage individuel (cellophane).
 Pour de plus amples détails, veuillez contacter notre service clients.

Techniques d'impression :



(SP) SÉRIGRAPHIE

Emballage externe :



500 ± 5,5 Kg

Regardez la vidéo



SACS

278 BIC® Drawstring Backpack

280 BIC® Classic Backpack

282 BIC® Multi-Use Pouch



BiC® **S a c s**

276 — 283





Sacs à dos multifonctionnels et accessoires utiles
au design moderne .

3450



Commande minimale 25u.

Personnalisation :

BIC® DRAWSTRING BACKPACK

3450

A SP: max. 2 col.

B OT: transfert numérique

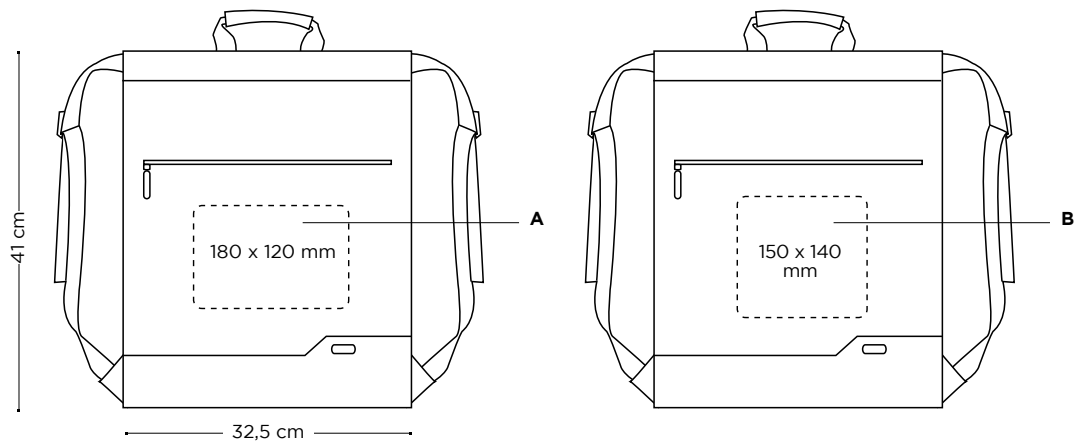

Techniques d'impression :

Emballage externe :



Regardez la video



(SP)
SÉRIGRAPHIE



(OT)
Transfert
numérique



50 ± 6,8 Kg

3451



12

03

59

25

02



Commande minimale 25u.

Personnalisation :

BIC® CLASSIC BACKPACK

3451

A SP: max. 2 col.

B OT: transfert numérique

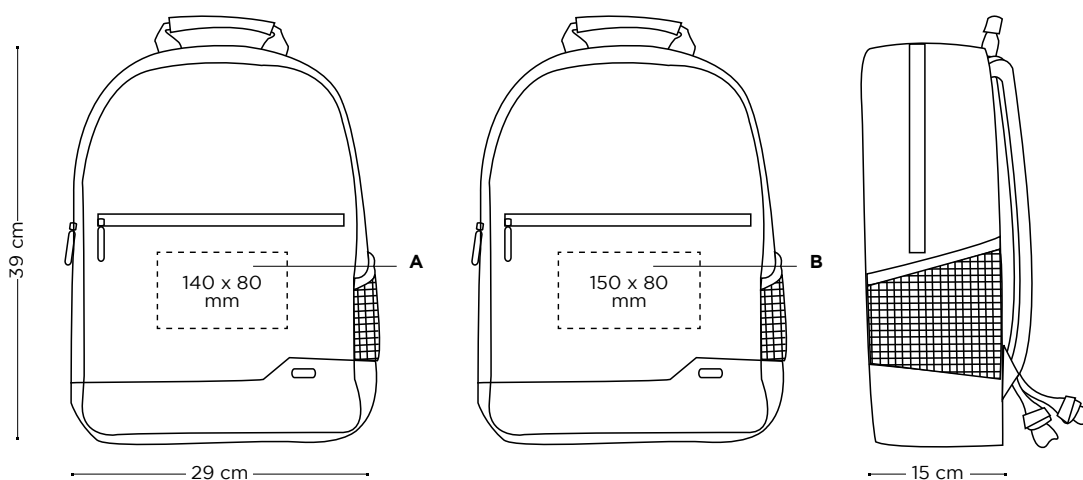

Techniques d'impression :

Emballage externe :



Regardez la video



(SP)
SÉRIGRAPHIE



(OT)
Transfert
numérique



25 ± 8,7 Kg

3452



12

03

59

25

02



Commande minimale 50u.

Personnalisation :

BIC® MULTI-USE POUCH

3452

A SP: max. 1 col.

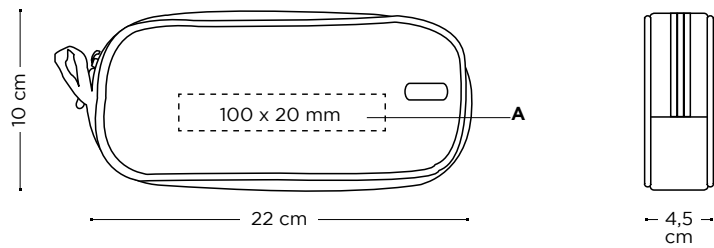

Techniques d'impression :



(SP)
SÉRIGRAPHIE

Emballage externe :



100 ± 5,8 Kg



Regardez la video

TECHNOLOGIE

286 Mouse Pad

T'NB

287 T'NB Lumy Wireless Mouse
& T'NB Lumy Wired Mouse

288 T'NB Rainbow Mouse

289 T'NB Stone Powerbank
41000 mAh & 6600 mAh

290 T'NB Ultra-Slim Powerbanks
4000 mAh & MFI Adapter

291 T'NB Slim Piowerbank
6000 mAh

SKROSS

292 SKROSS World To
Europe USB

293 SKROSS Pro Light USB

294 SKROSS World Adapter
MUV USB

Technologie

286 — 294

15031



60%

Technologie

Commande minimale 50u.

Personnalisation :

MOUSE PAD

15031

A SU: Quadrichromie

17,8 cm

178 x 228 mm

22,8 cm

Techniques d'impression :



(SU)
SUBLIMATION

Emballage externe :



200 ± 9 Kg



Commande minimale 10u.



Retrouvez de l'énergie et de la bonne humeur !



09697.10



09666.10

Longueur du cordon 135 cm

Personnalisation :

T'nB® LUMY WIRELESS MOUSE & T'nB® LUMY WIRED MOUSE

09697 / 09666

A BP: avant, pleines couleurs

B BPT: avant, pleines couleurs

C PD: avant, max 1 col

Profitez de l'effet relaxant du rétro-éclairage LED à couleur changeante

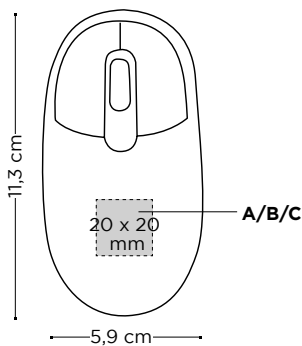

09697

Souris sans fil type "luminothérapie" qui grâce à ses 8 couleurs changeantes vous détendra même au travail.

Dans un souci d'économie et d'optimisation de la durée d'utilisation de la pile, la souris dispose d'un bouton ON/OFF et un mode veille automatique.



09666

Souris optique avec câble de 1000 DPI et effet relaxant à la lumière LED changeante avec 7 couleurs en alternance. Deux boutons et une molette avec clic.

Compatible avec PC/MAC®. Connexion USB.



Techniques d'impression :

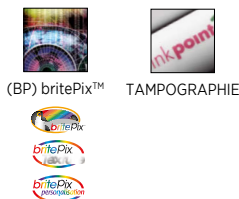

Emballage :



09697

09666

Emballage externe :



100 ± 14 Kg

Regardez la video



Commande minimale 10u.



.20

*souris fun et colorée
avec cable*



80%

.32



.30

Personnalisation :

T'nB® RAINBOW MOUSE

09699

A BP: avant boîte, quadrichromie

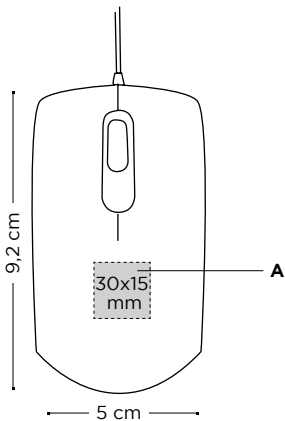

Cette souris colorée, 1000 dpi, est dotée de 2 boutons et scroll cliquables. Profitez d'un design fun et bicolore et un cable USB de la même couleur que le corps de la souris.

Techniques d'impression :



(BP) britePix™



Emballage :



Emballage externe :



100 ± 10 Kg

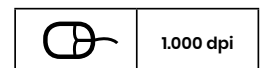

Commande minimale 10u.



A l'apparence d'une vraie pierre

Pochette en velours incluse



09664 .31



09665 .31

Personnalisation :

T'nB® STONE POWERBANK 4000 MAH
09664
A BP: avant, pleines couleurs
B BPT: avant, pleines couleurs

T'nB® STONE POWERBANK 6600 MAH
09665
A BP: avant, pleines couleurs
B BPT: avant, pleines couleurs

câble micro USB inclus

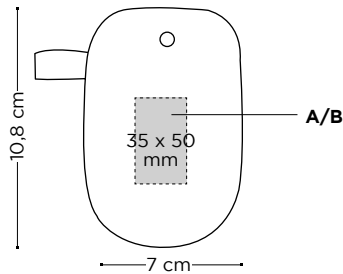
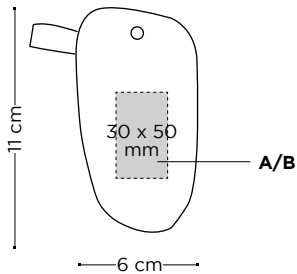

Batterie externe compacte en forme de pierre. Le niveau de charge est indiqué au moyen de 4 lumières. Câble micro USB inclus.

Techniques d'impression :

Emballage :

Emballage externe :

Regardez la video



(BP) britePix™



60 ± 8,6 Kg



09664

09665



Commande minimale 10 u.



Seulement 8 mm d'épaisseur !



Personnalisation :

T'nB® ULTRA-SLIM POWER BANK 4000 MFI 09701

- A BP: avant, pleines couleurs
- B BPT: avant, pleines couleurs

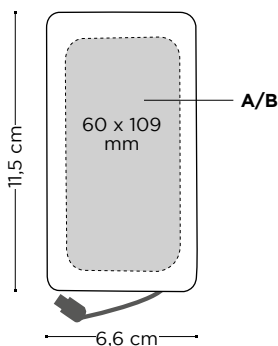

T'nB® ULTRA-SLIM POWERBANK 4000 MAH 09702

- C BP: avant, pleines couleurs
- D BPT: avant, pleines couleurs

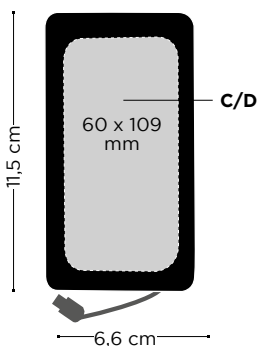

Batterie externe ultra plate 4000 mAh avec câble micro USB intégré. Cette batterie externe ultra plate et compacte se glissera facilement dans votre sac ou dans votre valise grâce à ses 8 mm d'épaisseur. Vous pouvez tripler l'autonomie de votre smartphone en fonction du modèle. De plus, grâce à son câble micro USB intégré, rechargez-la en un geste, où que vous soyez.

Techniques d'impression :

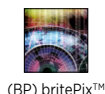

(BP) britePix™



Emballage :



Emballage externe :

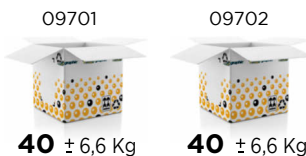

Commande minimale 10u.



seulement 15 mm d'épaisseur !



Personnalisation :

T'nB® SLIM POWER BANK 6000 MAH

09703

A BP: avant, pleines couleurs

B BPT: avant, pleines couleurs

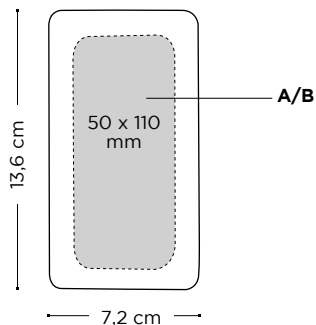

Cette batterie nomade slim et compacte 6000 mAh se glissera facilement dans votre sac grâce à sa finesse de 15mm. Vous pouvez quadrupler l'autonomie de votre Smartphone (en fonction du modèle). De plus, grâce à son câble USB + micro USB intégré, rechargez aussi bien la batterie nomade que votre Smartphone et ce où que vous soyez. Si vous possédez un iPhone®, utilisez le port USB situé sur le côté.

Techniques d'impression :



(BP) britePix™



Emballage :



Emballage externe :



Commande minimale 10u.



Le monde entier chez soi, en Europe !



Personnalisation :

WORLD TO EUROPE USB

*USB 09677

A PD: max. 2 col.

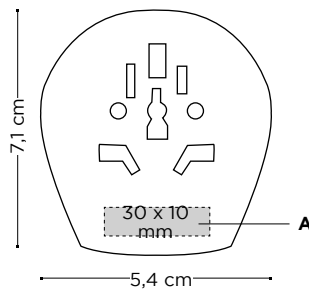

Connexion facile et fiable à la prise standard européenne pour les dispositifs du monde entier, avec chargeur USB incorporé pouvant être utilisé simultanément. Convient pour des équipements avec des prises raccordées ou non à la terre (à 2 et 3 pôles) et des dispositifs USB. Entrées pour : Suisse, Italie, Australie/Chine, Royaume-Uni, USA/Japon et Brésil.

Techniques d'impression :



TAMPOGRAPHIE

Emballage :



Emballage externe :



50 ± 3 Kg

Regardez la video



Commande minimale 10u.



Le plus petit des adaptateurs de voyage à 3 pôles avec chargeur USB intégré !



.10



Personnalisation :

PRO LIGHT USB

*USB 09678

A PD: max. 2 col.

B PD: max. 2 col.

C PD: max. 2 col.

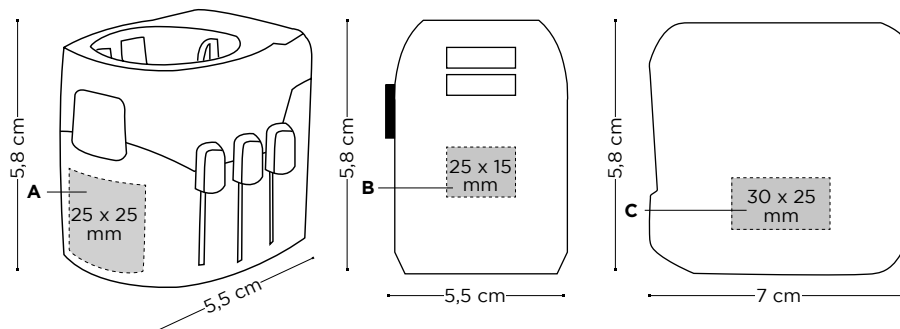

Adaptateur de voyage à 3 pôles ultra-compact pouvant être utilisé dans plus de 100 pays et servant aussi bien de prise de voyage que de chargeur USB pour les voyageurs européens. Convient pour connecter des dispositifs puissants tels que portables ou sèche-cheveux de voyage, et pour charger deux smartphones en même temps via USB.

Techniques d'impression : Emballage :



TAMPOGRAPHIE



Emballage externe :



50 ± 7,2 Kg

Commande minimale 10 u.



.10

120%



Personnalisation :

WORLD ADAPTER MUV USB

*USB 09474

A PD: max. 2 col.

B PD: max. 2 col.

C PD: max. 2 col.

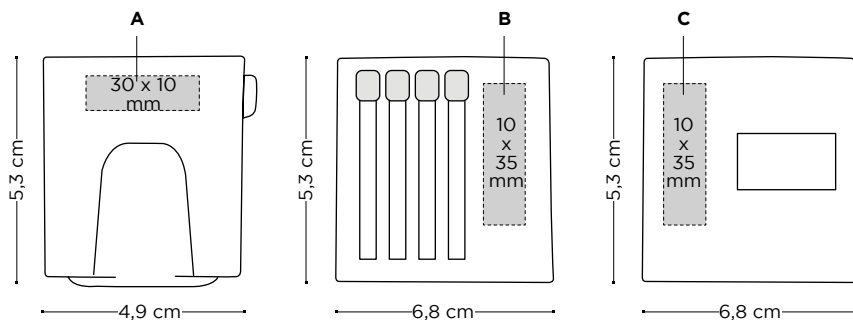

Cet adaptateur innovant à 2 pôles peut être utilisé dans plus de 220 pays et sert à la fois d'adaptateur de voyage et de chargeur USB. Grâce à la grande capacité de charge de sa batterie (2400 mA), vous pouvez brancher en même temps un appareil équipé d'une prise à 2 pôles et deux appareils USB.

Techniques d'impression : Emballage :



TAMPOGRAPHIE



Emballage externe :



50 ± 11,8 Kg



Emballages

296 — 300

EMBALLAGES

296 BIC® Emballage

BIC ECO SLEEVE *Nouveau !*

985240

Pochette spéciale recyclée pour tous les instruments d'écriture BIC® à l'exception des crayons papier.



RECYCLED CARDBOARD



FABRIQUÉ EN ESPAGNE



Emballage spécial pour stylos avec clip imprimé:

- BIC** MEDIA CLIC
- BIC** WIDE BODY
- BIC** CLIC STICK
- BIC** ATLANTIS
- BIC** SUPER CLIP
- BIC** FINE STYLE

Découvrez l'initiative Treadom:



BIC WINDOW BOX *Nouveau !*

985241

Emballage design haut de gamme pour tous les instruments d'écriture BIC® à l'exception des crayons papier.

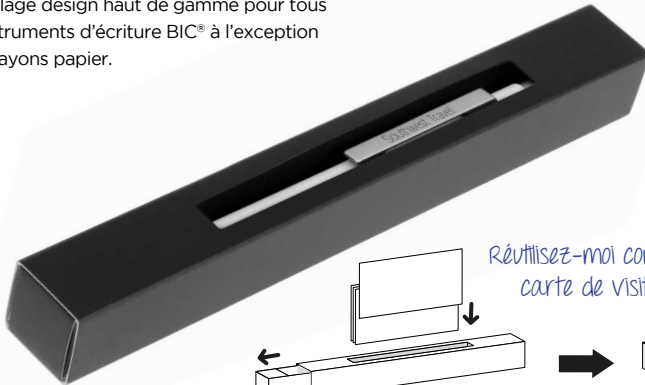

Réutilisez-moi comme carte de visite



www.fsc.org



FABRIQUÉ EN ESPAGNE



Emballage spécial pour:

- BIC** METAL PENS

Découvrez l'initiative Treadom:



BIC PLASTIC POUCH *Nouveau !*

985242

Design spécial pour cet emballage qui s'adapte à tous les instruments d'écriture et pour 3 crayons papier.



www.fsc.org



PLASTIQUE RECYCLABLE



FABRIQUÉ EN ESPAGNE

Utilisez-moi comme marque-page



BIC MARKING SET *Nouveau !*

985243

Emballage conçu pour tous les types de stylos marqueurs.

Prix (€)
0,65



PLASTIQUE RECYCLABLE
FABRIQUÉ EN ESPAGNE



Emballage spécial pour stylos avec clip imprimé:

- BIC** 3 BRITELINER
- BIC** 3 Velleda GRIP
- BIC** 3 MARK-IT
- BIC** 4 Velleda FINE

Utilisez-moi comme
marque-page



BIC GIFT BOX *Nouveau !*

985241

Set spécial pour cahiers et instruments d'écriture.

Prix (€)
A5 2,05
A6 1,90



FABRIQUÉ EN ESPAGNE



Emballage spécial pour
cahiers Dual A5 et A6 et:

- BIC** 4-COLOURS (SP)
- BIC** MEDIA CLIC (SP)
- BIC** SUPER CLIP (SP)

BIC CELLO WRAP

971634 - 971635 - 971636 - 971637

Emballage enveloppe en matière plastique résistante et transparente.



Non disponible pour les crayons papier ou les stylos métal. En raison des différents procédés d'impression, les couleurs de marquage sur les stylos et les blocs-notes peuvent légèrement différer.

BIC FROSTED POUCH (FOR 1 OR 2 ITEMS)

971640

Emballage transparent pour 2 instruments d'écriture.

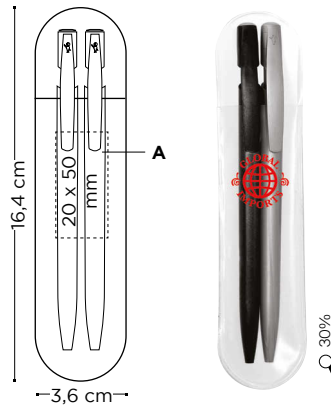

Frais d'impression supplémentaires par couleur et position SP

Disponible pour tous les instruments d'écriture, sauf crayons papier et porte-mines.

A SP: max. 1 col.



(SP) SÉRIGRAPHIE

Jusqu'à épuisement de stock

BIC BLACK VELVET POUCH 1 ITEM

974216

Emballage exclusif en velours pour 1 ou 2 instruments d'écriture. Spécialement recommandé pour les stylos métal.

BIC BLACK VELVET POUCH FOR SET

974217

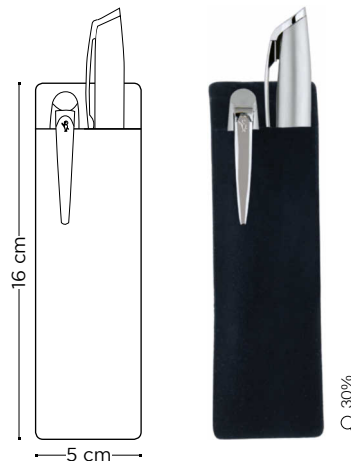
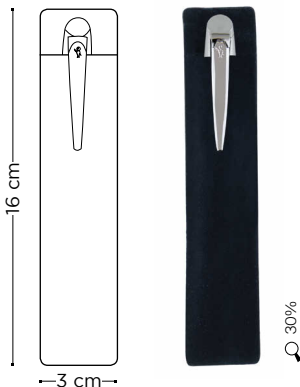

Disponible pour tous les instruments d'écriture, sauf crayons papier et porte-mines.

BIC CARTON BLACK & SILVER COLOUR GIFT BOX

974218

Boîte pour tous les instruments d'écriture, sauf les crayons papier.



(Jusqu'à épuisement du stock)

BIC BLACK TWO PIECE GIFT BOX FOR 1 ITEM

974214

Boîte pour tous les instruments d'écriture, sauf les crayons papier.

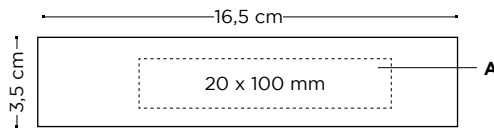

Disponible pour tous les instruments d'écriture, sauf crayons papier et porte-mines.

A SP: max. 1 col.



(SP)
SÉRIGRAPHIE

(Jusqu'à épuisement du stock)

BIC SEE-THROUGH GIFT BOX (FOR 1 OR 2 ITEMS)

974599

Boîte pour tous les instruments d'écriture, sauf les crayons papier.



(Jusqu'à épuisement du stock)

BIC COTTON DRAWSTING POUCH

974458

Sac coton spécialement conçu pour tous les instruments d'écriture avec personnalisation spéciale.

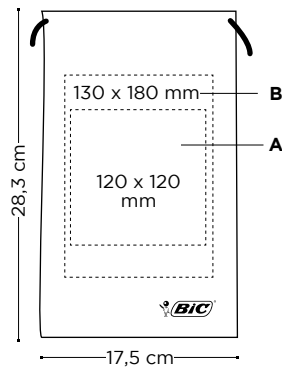

A SP: max. 2 col.
A OT: Numérique



(SP)
SÉRIGRAPHIE



(OT)
TRANSFERT
NUMÉRIQUE

COUNT BOX

Petit
 (pour 25 BIC® Clic Stic)
 Moyen
 (pour 50 BIC® Media clic ou similaire)
 Grand
 (uniquement pour 100 BIC® Ecolutions Evolution)



PLASTIC BAG

Petit
 (pour 25 BIC® Media clic ou similaire)
 Moyen
 (pour 50 BIC® Media clic ou similaire)
 Grand
 (pour 100 BIC® Media clic ou similaire)



TRAY OF 10 WRITING INSTRUMENTS



COUNT BOX 10U CASES



COUNT BOX 10U CASES CHILD RESISTANT



COUNT BOX 10U J25 CHILD RESISTANT



BOX OF 50 METAL STYL'IT CASE



Disponible pour la famille des BIC® Styl'it Luxury Lighter Case et des BIC® Aluminium Flat Case.

Disponible pour les briquets BIC® J26, BIC® J38 et BIC® J39 .

Disponible pour le briquet BIC® J25.

Disponible pour les coques BIC® Clip Case, BIC® Styl'it, Fashion Case et BIC® 3D Case.

BIC OUTER BOXES

Design spéciale pour toutes les boîtes extérieures liées à tous les instruments d'écriture.



Informations générales

302 — 309

- 302** Commandez en toute simplicité!
- 303** Service d'impression en 48 heures
- 304** Informations générales sur les notes adhésives
- 305** Symboles et abréviations
- 306** Informations générales
- 307** Paramètres techniques pour chacun des types d'impression
- 309** Nuancier de couleurs

STICKY NOTES GENERAL INFORMATION



En raison de la nature du papier BIC® Sticky Notes, les résultats à l'impression auront un aspect mat, et non brillant. Les couleurs de référence choisies doivent être sélectionnées dans le guide d'une couleur spécifique. **Les BIC® Sticky Notes sont imprimés en quadrichromie (CMYK), une technique qui ajuste la couleur d'impression afin de correspondre aux références d'une couleur spécifique.**

Pour toute demande d'une couleur spécifique, nous pouvons proposer une impression avec une 5e couleur de ce Guide, à un prix majoré. Pour plus d'informations sur la manière d'obtenir la couleur correspondante la plus proche pour des impressions sur différents produits de notre catalogue, veuillez contacter notre service client.



ZONE D'IMPRESSION

Même si la partie supérieure du bloc de papier peut être imprimée (la partie adhésive), elle peut seulement être imprimée jusqu'à 60 % d'encre totale. Indépendamment de la zone adhésive, nous recommandons d'imprimer uniquement 30 % de la surface du produit afin de laisser de l'espace pour la prise de notes et d'éviter ainsi d'éventuelles problèmes d'adhésion de l'encre sur le papier.

FORMES SPÉCIALES D'ESTAMPAGE ET AUTRES PERSONNALISATIONS

Soyez le plus original ! Demandez vos blocs adhésifs BIC® Sticky Notes avec votre forme personnalisée ou adaptez-les en incluant votre propre logo sur le verso des blocs. Veuillez vérifier les conditions de ces formules spéciales avec votre contact habituel.

IMPRESSION SHADOW OU FANTÔME

Les impressions Shadow ou fantôme sont disponibles sans surcoût. Les photographies, les dessins ou logos de grande taille qui couvrent la majorité de la surface centrale ont un meilleur rendu. Comme ces impressions sont très claires, les textes et numéros de téléphone ne sont pas recommandés en Shadow ou fantôme. Les meilleurs rendus sont obtenus à partir d'images tramées aux environs de 10 %.



SYMBOLES ET ABRÉVIATIONS

OPTIONS SPÉCIALES



Puffy glitter
Texture avec paillettes colorée.



Puffy Printing
Une personnalisation soulignée par notre encre « Puffy », pour donner un effet de relief à votre logo.



4-Colour Process
Permet la reproduction d'images de haute résolution. Idéal pour la reproduction de photographies. Original et attrayant



BR
Finition brillante.



Glow in the dark
Faites étinceller votre marque même dans le noir.



Metallic Finish
Crée des effets métalliques sur les images ou l'arrière-plan.



Holographic Finish
Transformez votre logo en 3D.



Matt
Finition mate.



UV
Finition extra brillante.



Sandy
Effet papier de verre, avec une texture granuleuse.



Digital
Quadrichromie haute définition, à 360° degrés et sur toute la longueur du corps du crayon.



britePix™
Votre message peut maintenant être imprimé en quadrichromie et d'une excellente qualité image afin de produire une impression durable et persistante de votre logo.



britePix™ Texture
britePix™ Texture apporte une nouvelle touche haut de gamme au concept britePix™. Désormais, vous pouvez non seulement voir tout en couleur, mais aussi le toucher !



britePix™ personnalisation
Personnalisation britePix™
Personnalisez chaque unité dans une seule et même commande.

ABRÉVIATIONS

SP = Sérigraphie
LE = Gravure laser
HS = Marquage à chaud
DB = Embossage
PD = Tampographie
DG = Quadrichromie
BP = britePix™
BP Texture = britePix™ Texture
OT = Transfert offset
MOQ = Quantité minimum de marquage
3D = 3D embossage
SU = Sublimation

COULEURS D'ENCRE

Encre noire
 Bleu Pastel
 Encre bleue claire
 Encre bleue foncée
 Encre rouge
 Orange
 Jaune
 Jaune Pastel
 Encre verte claire
 Vert Pastel
 Vert pomme
 Encre verte foncée
 Encre Fluo
 Rose corail
 Encre rose
 Violet Pastel
 Encre violette



BIC® Easy-Glide system option
Offre une encre qui est 35 % plus lisse et plus épaisse que votre stylo à bille actuel.

MODES D'ECRITURE

M Medium
 F Fine
 B Bold
 SP Stylo Plume
 MP Porte-mine
 PC Crayon
 R Stylo à bille roulante
 MK Marqueur
 SP Stylo Plume
 FS Surligneur
 HL Feutre pointe fine
 T Tipp-Ex®
 G Gel

AUTRES SYMBOLES



Mix&Match
Des centaines de couleurs de composants en stock pour la personnalisation complète des instruments d'écriture.



Injection d'une couleur spécifique
Choisissez la couleur exacte pour des décorations les mieux adaptées à votre logo.



QR code
scannez le QR code et visionnez la vidéo.



48-Hour
Service 48 h disponible.



Möbius Loop
Le produit contient des matériaux recyclés. Si vous voulez plus informations sur notre BIC® Ecolutions® et son mode de fabrication bicgraphic.eu/ie/sustainable-development.html



FSC
Produit fabriqué avec des matériaux respectant l'environnement, utilisant des matériaux renouvelables de conifères (polymères cellulosiques).



Pays d'origine



APP
Téléchargez l'application de BIC® Graphic et scannez les pages où figure cette icône.



Nouveau / Nouvelle couleur !



EN 13869
Règlement de sécurité des enfants pour les briquets.



ISO 22702
Cette norme certifie la qualité de tous les briquets à usages multiples.



ISO 9994
Normes de sécurité internationales pour les briquets.



Sticky Notes
Nombre de pages.



Notebooks
Nombre de pages.



Informations sur l'emballage



BIC® Boy
Iconic BIC® Boy est embossé



Bande lubrifiante



Nombre de lames



BIC® Mega Lighter
usage quotidien du BIC® Mega Lighter.



Nombre d'allumages



Tube de gel à raser 10 ml uniquement disponible pour l'Autriche, la Belgique, la France, l'Allemagne, l'Italie, le Luxembourg, les Pays-Bas, le Portugal, la Roumanie, l'Espagne, la Suisse et le Royaume-Uni.



Exclusive
Articles exclusifs disponibles seulement dans notre catalogue.



Bluetooth®



Autonomie de la batterie



Wireless



Entrée/sortie alimentation



Point par pouces

DIMENSIONS Les dimensions publiées de tous les produits correspondent à la taille maximale, quelle que soit la position du dessin.